

Serie ESM 60

Massbild (Zoll in Klammern) / Outline drawing (inch. in bracket)

Bohrplan / Cut out

<sup>3)</sup> Auf Anfrage / On request

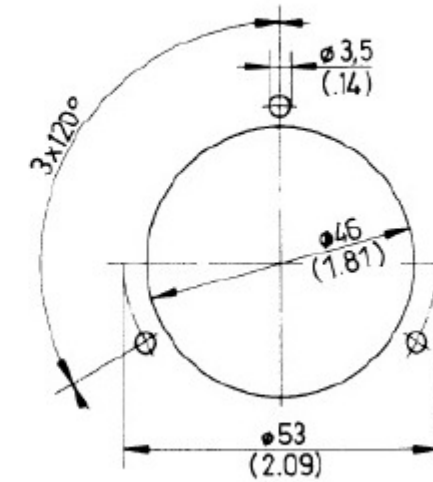
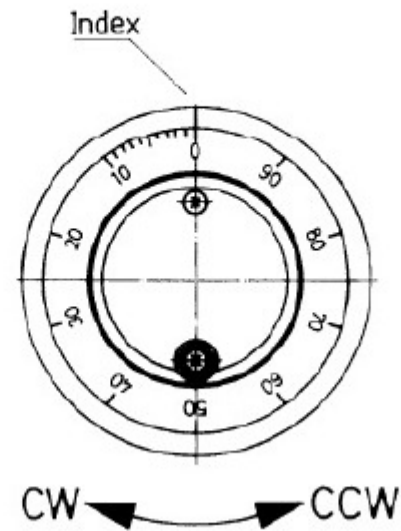
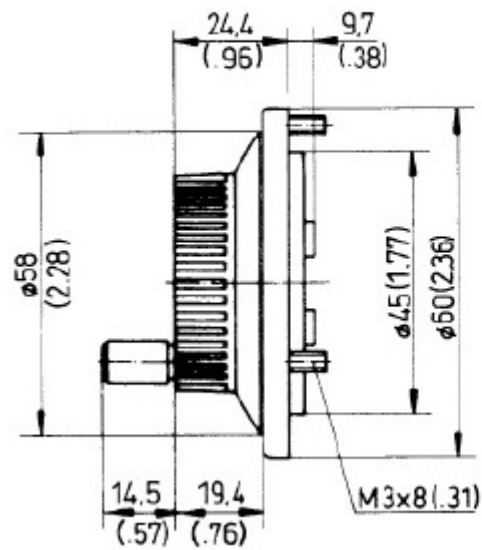

**Serie ESM 60**

Eingangsuntersetzung (mehrstufig) / Input ratio (more stages)

M x:1

$\phi d = 9\text{-}h8$      $s = 8,5$      $F = \Rightarrow 40\text{ N } \nabla 80\text{ N}$     MS = Montagefläche / Mounting surface

L = Mass, siehe Anzahl Schalter / Dimension, please see number of switches  
H = 16 mm (Typ CP22) / 17,8 mm (Typ CP36)

