

Kompakt ESA 36

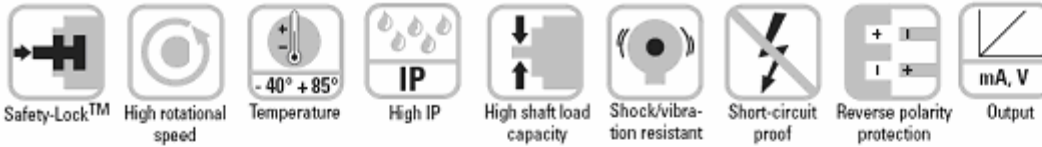

Rugged

- Ensures long service life and reliability of the application, no wear
Non-contact measuring system
- Stays sealed even when subjected to harsh everyday use. Offers security against failures in the field
Solid die-cast housing with up to IP 69K protection
- Can be used for a wide temperature range without additional expense.
Wide temperature range (-40 °C ... +85 °C)
- Increased ability to withstand vibration and installation errors. Eliminates machine downtime and repairs.
High shock resistance (> 500g) and vibration resistance (>30g)
- Can be used in outdoor applications with large fluctuations in temperature.
Resistant against humidity and condensation.



Compact

- Can be used where space is tight
Overall diameter of only 36 mm
- Compact encoder can be used on large diameter shafts
Fixing holes on D26 mm

Versatile

- Interface: 9-Bit SSI, 4 ... 20 mA, 0 ... 10 V
One size available for different applications
- Measuring range: 45°; 90°; 180°; 360°:
Suitable measuring range available for different applications
- Enables simple installation
Reference point can be identified via LED (green)
- Easy diagnosis in case of fault condition
Error indication via LED (red)
- Can be fixed on various diameters
Fixing holes on D 26mm and D 30mm

Mechanical characteristics:

Max. speed:	6000 min ⁻¹
Starting torque	< 0,06 Nm
Radial load capacity of shaft:	40 N
Axial load capacity of shaft:	20 N
Weight:	approx. 0,2 kg
Protection acc. to EN 60 529:	IP 67 (IP 69k on request)
Working temperature range:	-40 °C ... +85 °C
Materials:	Shaft: stainless steel, Flange: aluminium, Housing: die cast zinc, Cable: PUR
Shock resistance acc. to DIN-IEC 68-2-27:	5000 m/s ² , 6 ms
Vibration resistance acc. to DIN-IEC 68-2-6:	300 m/s ² , 10 ... 2000 Hz
Permanent shock resistance acc. to DIN-IEC 68-2-29	1000 m/s ² , 2 ms
Vibration (broad-band random) to DIN-IEC 68-2-64	5 ... 2500 Hz, 100 m/s ² - rms

All-round protection thanks to Safety-Lock^{plus}™ and Sensor-Protect™ technology

Safety-Lock^{plus}™:
IP69k protection on the flange side, robust bearing assemblies with interlocking bearings, mechanically protected shaft seal

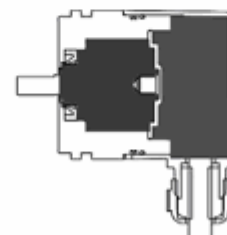

Sensor-Protect™:
Fully encapsulated electronics, separate mechanical bearing assembly

Kompakt ESA 36

Electrical characteristics SSI Interface:

Sensor:	
Supply voltage:	5 ... 30 V DC ¹⁾
Current consumption (w/o output load):	typ 22 mA, max. 41 mA
Reverse polarity protection at power supply (Ub):	Yes
Measuring range:	360°
Resolution/Code:	9 Bit/Binary
Linearity (25 °C)	<1.0 %
Repeat accuracy:	<0.2 %
Data refresh rate:	typ 100 µs
Status LED:	Green, reference point at 2,1°

SSI interface	
Clock speed:	100 kHz ... 750 kHz
Output driver:	RS 485
Monoflop time typ./max.:	16 µs/20 µs
Short circuit proof outputs:	Yes ²⁾
Permissible load/channel:	typ. 120 Ohm (corresponding RS 485)

- ¹⁾ The supply voltage at the encoder input must not be less than 4.75 V (5 V - 5%)
²⁾ Short circuit to 0V or to output, only one channel at a time, supply voltage correctly applied

Terminal assignment:

Sig.:	0V	+Ub	0 V Sens	+Ub Sens	+T	-T	+D	-D
Col.:	WH	BN	BU	RD	GN	YE	GY	PK

Electrical characteristics current interface 4 ... 20 mA:

Sensor:	
Supply voltage:	18 ... 30 V DC
Current consumption (w/o output load):	typ 25 mA, max. 42 mA
Reverse polarity protection at power supply (Ub):	Yes
Measuring range:	45°, 90°, 180° or 360° (see also table „measuring range“)
Linearity (25 °C)	<1.0 % (360 ° measurement range)
Repeat accuracy:	<0.2 % (360 ° measurement range)
Status LED:	Green: reference point at 2.1° Red: sensor break detection , Control power supply

4 ... 20 mA current loop	
Output load:	max. 500 ohms at 24 V DC
Setting time:	< 1 ms (R _{load} = 400 Ohm, 25 °C)
Short-circuit proof outputs: when the supply voltage is correctly applied, then output to output is short-circuit protected. But not output to 0 V or to +Ub	
Supply voltage and sensor output signal are not galvanically isolated.	

Example (output signal profile):
for range 90° cw

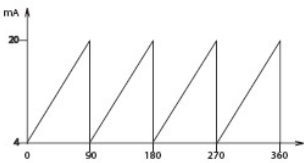

for range 180° ccw

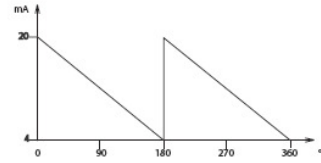

Terminal assignment:

Sig.:	0V	+Ub	+I	-I
Col.:	WH	BN	GN	YE

Electrical characteristics voltage interface 0 ... 10 V:

Sensor:	
Supply voltage:	20 ... 30 V DC
Current consumption: (w/o output load):	typ 27 mA, max. 47 mA
Reverse polarity protection at power supply (Ub):	Yes
Measuring range:	45°, 90°, 180° or 360° (see also table „measuring range“)
Linearity(25 °C)	<1.0 % (360 ° measurement range)
Repeat accuracy:	<0.2 % (360 ° measurement range)
Status LED:	Green: reference point at 2.1°

0 ... 10 V voltage output	
Current output:	max. 10 mA
Setting time:	< 1 ms (R _{last} = 1 KOhm, 25 °C)
Short-circuit proof outputs:	Yes ²⁾
Supply voltage and sensor output signal are not galvanically isolated.	

- ²⁾Short circuit to 0V or to output, only one channel at a time, supply voltage correctly applied

Example (output signal profile):
for range 90° cw

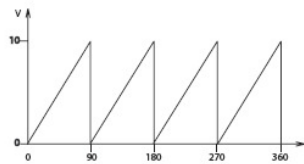

for range 180° ccw

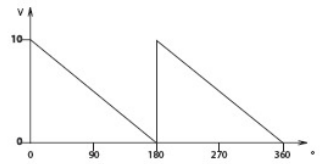

Terminal assignment:

Sig.:	0V	+Ub	+Uo	-Uo
Col.:	WH	BN	GN	YE

General characteristics:

Conforms to CE requirements acc. to EN 61000-6-1, EN 61000-6-4, EN 61000-6-3 and EN 61000-4-8 (behaviour under magnetic influence).

Kompakt ESA 36

Dimensions:
ø 36 mm, Synchro flange

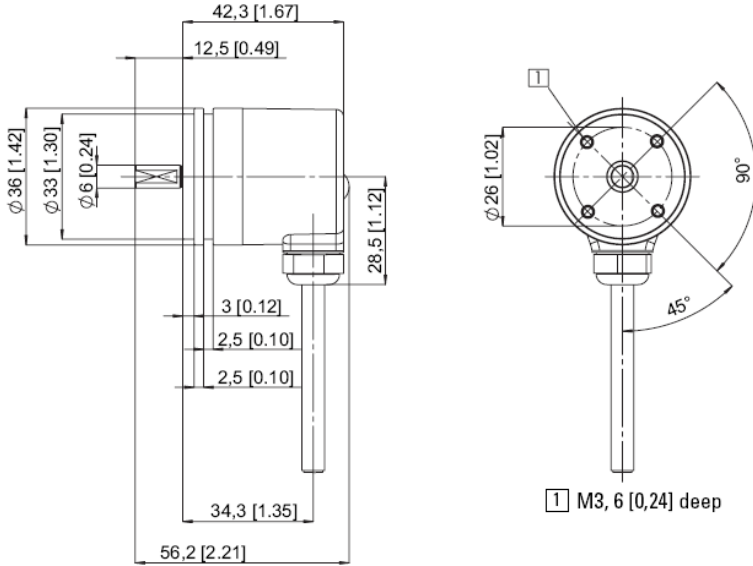

Order code:

ESA 36 . X X X X . X X X X

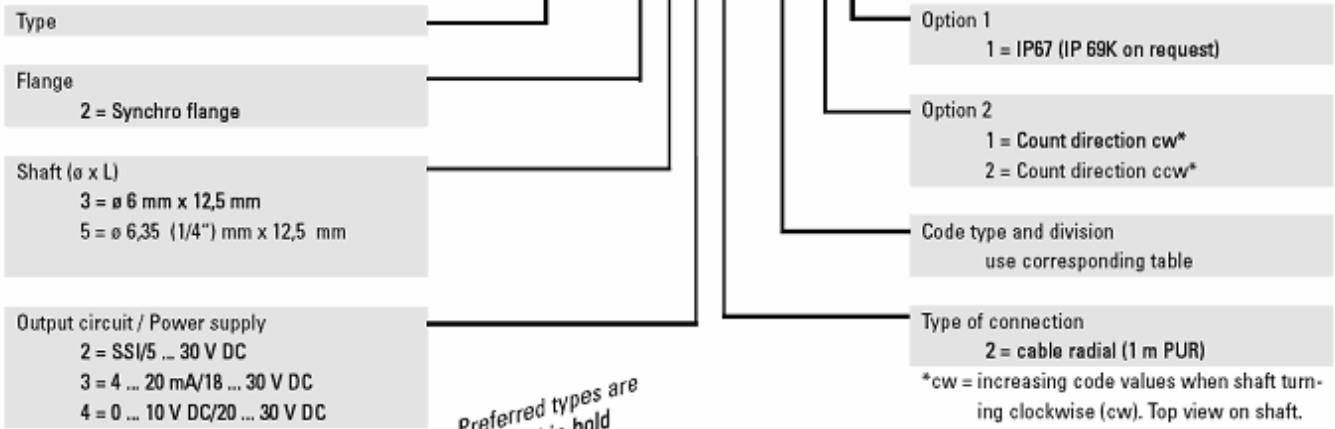

Preferred types are indicated in bold

Code type and division:

SSI interface
B9 = 9 Bit binary

Current interface 4 ... 20 mA
45 = 45° measurement range
90 = 90° measurement range
18 = 180° measurement range
36 = 360° measurement range

Voltage interface 0 ... 10 V
45 = 45° measurement range
90 = 90° measurement range
18 = 180° measurement range
36 = 360° measurement range

Measuring range:

Measuring range:	360°	180°	90°	45°
Internal resolution (Measuring range):	9 Bit	8 Bit	7 Bit	6 Bit
	512 steps	256 steps	128 steps	64 steps
Interfaces:	SSI	-	-	-
	4 ... 20 mA	4 ... 20 mA	4 ... 20 mA	4 ... 20 mA
	0 ... 10 V	0 ... 10 V	0 ... 10 V	0 ... 10 V