

**Kompakt ESA 36**

**Massbild / Outline drawing**

ø 36 mm, mit Drehmomentstütze

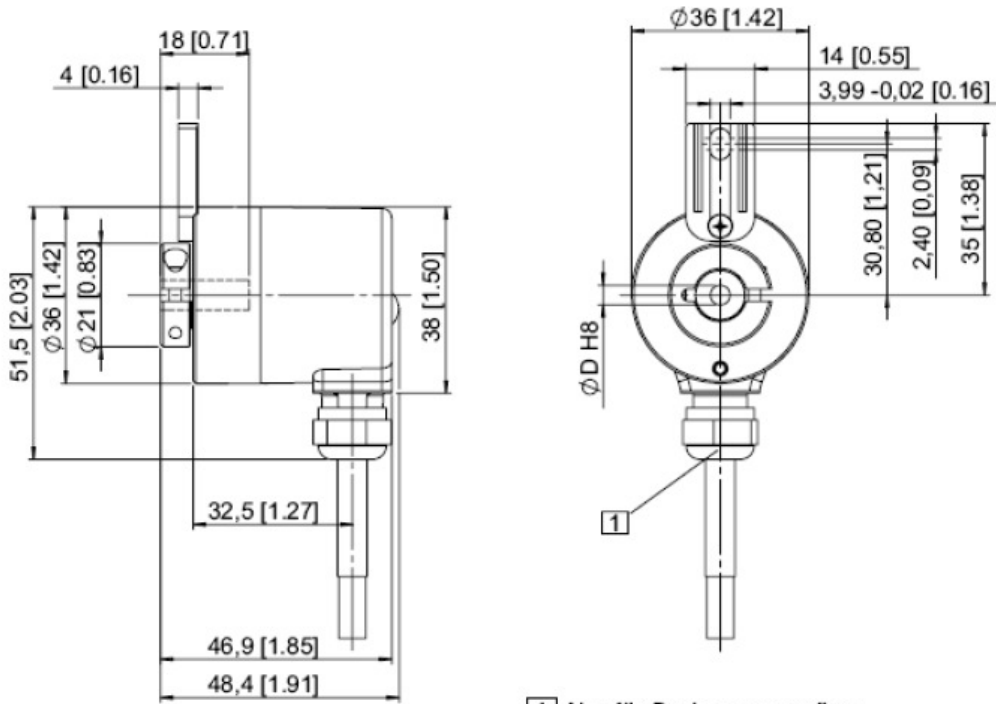

1 Nut für Drehmomentstütze,  
 Empfehlung: Zylinderstift nach DIN 7 04,0

ø 36 mm, Synchroflansch

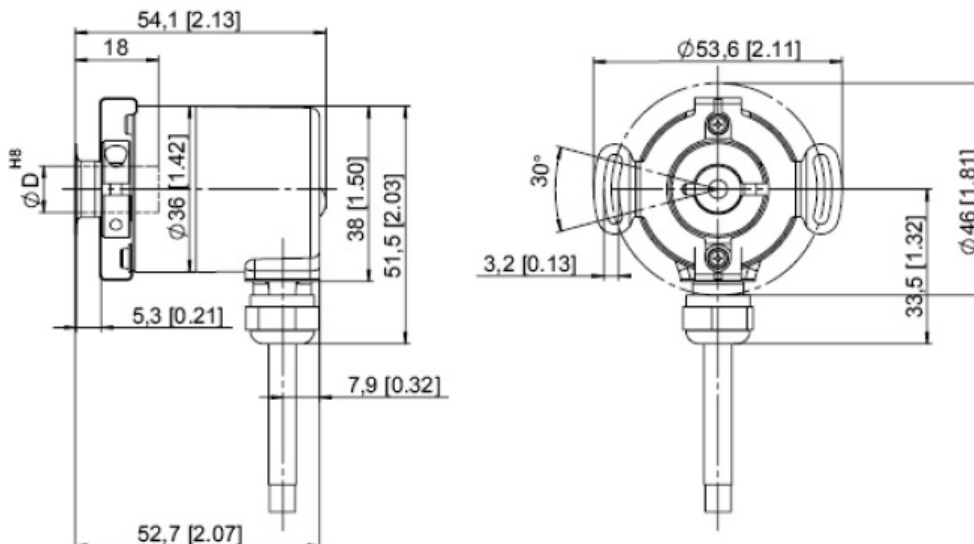

**Kompakt ESA 36**

ø 36 mm, Flange with long torque stop

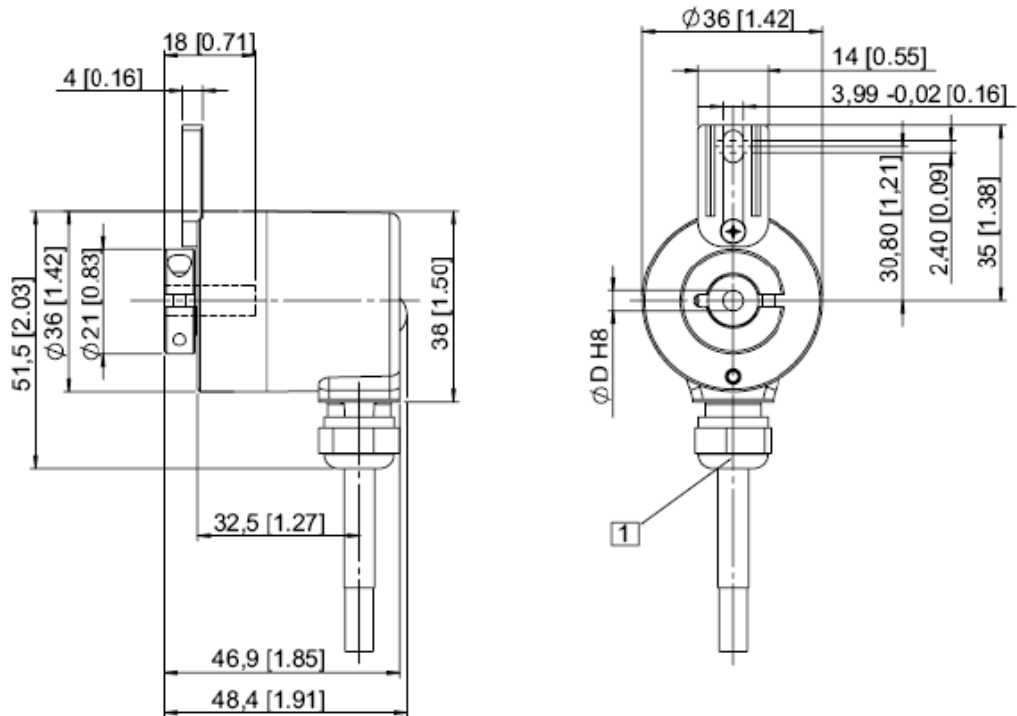

- 1 Torque stop slot,  
 Recommendation: cyl. pin. acc. DIN 7 04

ø 36 mm, Synchro flange

