

Grosse Hohlwelle ENI 100 SH

Massbild / Outline drawing

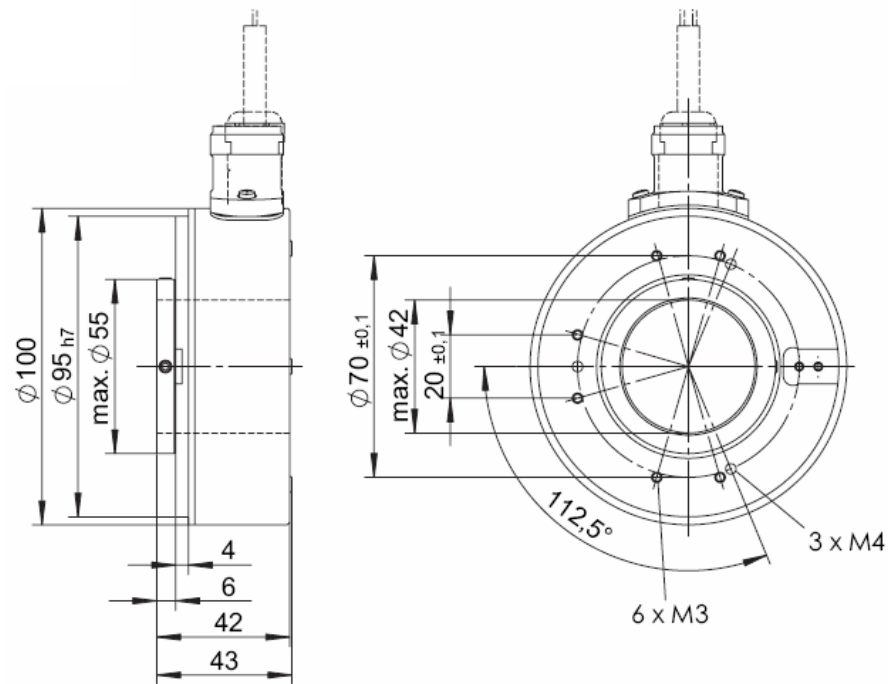

A Steckerausführung

A Plug version

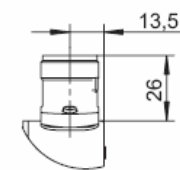
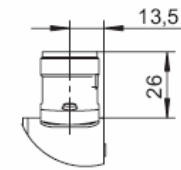

B Kabelausführung

B Cable version

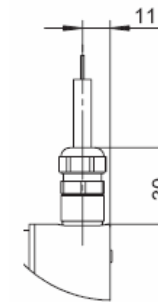
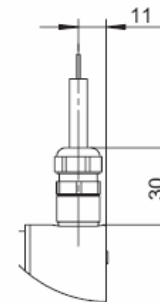

Incremental hollow shaft encoder
 Inkrementale Drehgeber in Hohlwellenausführung

Grosse Hohlwelle ENI 100 SH

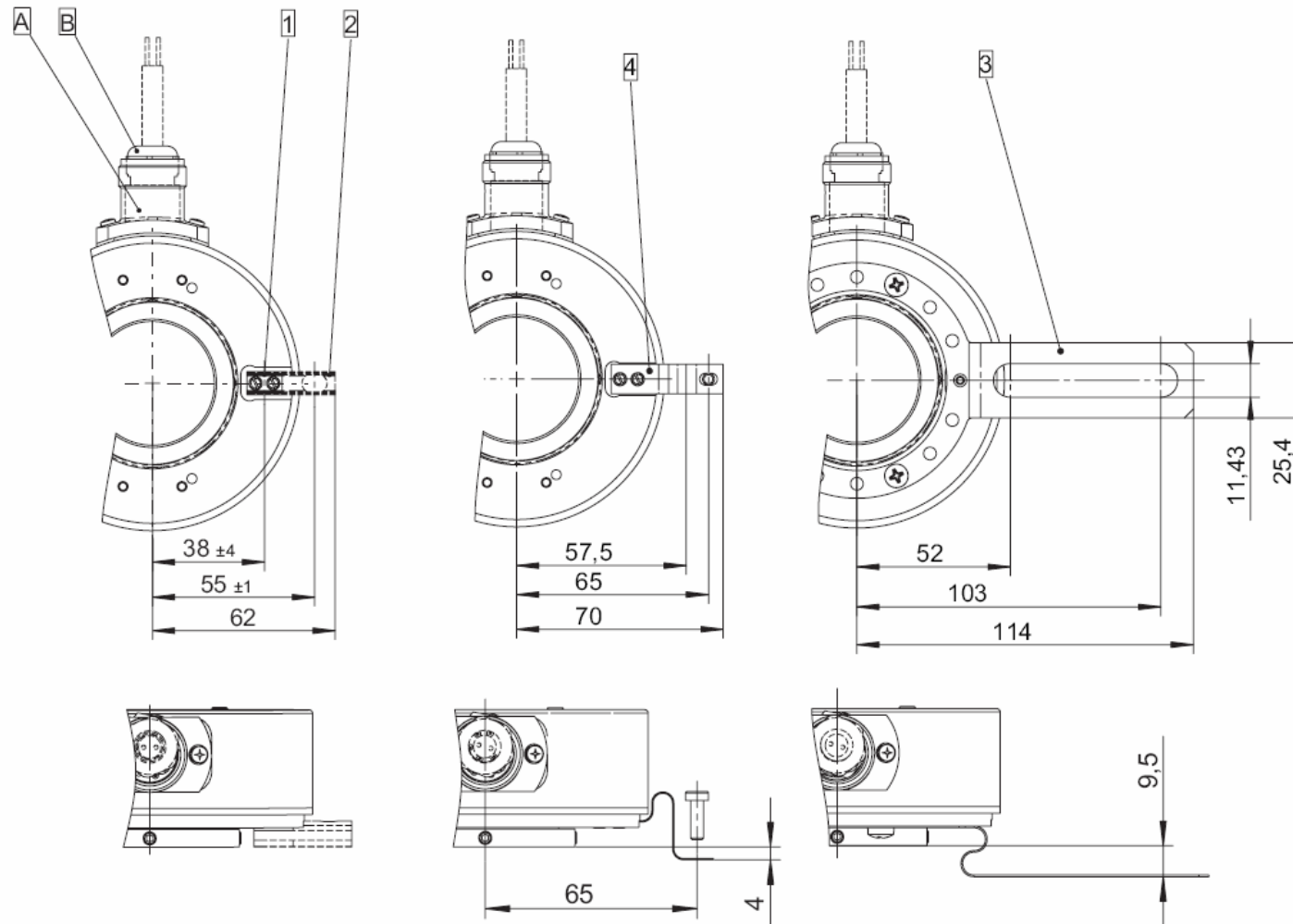

- 1 Federelement kurz (Flansch Nr. 2)
- 2 Federelement lang (Flansch Nr. 3)
- 3 Befestigungsarm lang
- 4 Befestigungswinkel

- 1 Spring element short (Bracket Nr. 2)
- 2 Spring element long (Bracket Nr. 3)
- 3 Tether arm long
- 4 Bracket

Hinweis: Minimale Einstecktiefe $1,5 \times D_{\text{Hohlwelle}}$
 Note: minimum insertion depth $1.5 \times D_{\text{hollow shaft}}$