

Incremental hollow shaft encoder Inkrementale Drehgeber in Hohlwellenausführung

Large Diameter ENI 100

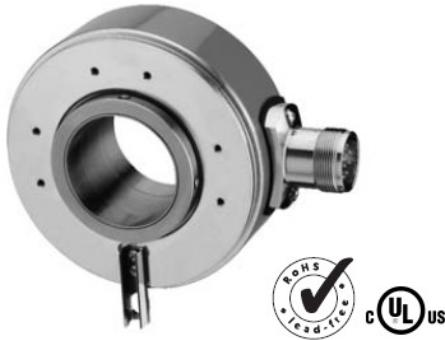

- Only 43 mm clearance needed
- Hollow shaft diameter up to 42 mm
- Very easy mounting. The encoder is mounted directly on the drive shaft without couplings.
- Electronic temperature and ageing compensation
- RS 422, push-pull or sine wave output
- High scanning rate

Mechanical characteristics:

Speed: ¹⁾	max. 3000 min ⁻¹
Rotor moment of inertia: ³⁾	<150 x 10 ⁻⁶ kgm ²
Starting torque with sealing:	< 0.2 Nm
Weight:	app. 0.7 kg
Protection acc. to EN 60 529:	IP 65
Working temperature:	-20° C ... +70 °C ²⁾
Operating temperature:	-20° C ... +75 °C ²⁾
Shaft:	stainless steel H7
Shock resistance acc. to DIN-IEC 68-2-27:	1000 m/s ² , 6 ms
Vibration resistance acc. to DIN-IEC 68-2-6:	100 m/s ² , 10...2000 Hz

Pulse rates available at short notice:

360*, 512, 600, 1000, 1024, 1500, 2048, 2500, 4096, 5000

*not with sine wave output

Other pulse rates on request

¹⁾ Short term (app. 15 min. range) up to 3500 min⁻¹ ²⁾ Non-condensing ³⁾ Depending on shaft diameter

Electrical characteristics RS 422 or push-pull output:

Output circuit:	RS 422 (TTL-compatible)	Push-pull	Push-pull (7272) ³⁾
Supply voltage:	5 V (±5 %) or 10 ... 30 V DC	10 ... 30 V DC	5 ... 30 V DC
Power consumption (no load) without inverted signal:	not available	typ. 55 mA / max. 125 mA	–
Power consumption (no load) with inverted signal:	typ. 40 mA / max. 90 mA	typ. 80 mA / max. 150 mA	typ. 50 mA / max. 100 mA
Permissible load/channel:	max. ±20 mA	max. ±30 mA	max. ±20 mA
Pulse frequency:	max. 300 kHz	max. 300 kHz	max. 300 kHz
Signal level high:	min. 2.5 V	min. U _B -3 V	min. U _B -2.0 V
Signal level low:	max. 0.5 V	max. 2.5 V	max. 0.5 V
Rise time t _r	max. 200 ns	max. 1 μs	max. 1 μs
Fall time t _f	max. 200 ns	max. 1 μs	max. 1 μs
Short circuit proof outputs ¹⁾ :	yes ²⁾	yes	yes
Reverse connection protection at U _B :	5 V: no, 10 ... 30 V: yes	yes	no
Conforms to CE requirements acc. to EN 61000-6-1, EN 61000-6-4 and EN 61000-6-3			

¹⁾ If supply voltage correctly applied

²⁾ Only one channel allowed to be shorted-out:
(If U_B=5 V, short-circuit to channel, 0 V, or +U_B is permitted)
(If U_B=5-30 V, short-circuit to channel or 0 V is permitted)

³⁾ Max. recommended cable length 30 m

Electrical characteristics sine wave output:

Output circuit:	Sine	Sine
	U = 1 V _{SS}	U = 1 V _{SS}
Supply voltage:	5 V (±5 %)	10 ... 30 V DC
Current consumption (no load) with inverted signals:	typ. 65 mA / max. 110 mA	typ. 65 mA / max. 110 mA
-3 dB frequency:	≥180 kHz	≥180 kHz
Signal level channels A/B:	1 V _{SS} (±20%)	1 V _{SS} (±20 %)
Signal level channel 0:	0.1 ... 1.2 V	0.1 ... 1.2 V
Short circuit proof outputs ¹⁾ :	yes	yes
Reverse connection protection at U _B :	no	yes
Conforms to CE requirements acc. to EN 61000-6-1, EN 61000-6-4 and EN 61000-6-3		

¹⁾ If supply voltage correctly applied

Large Diameter ENI 100

Dimensions:

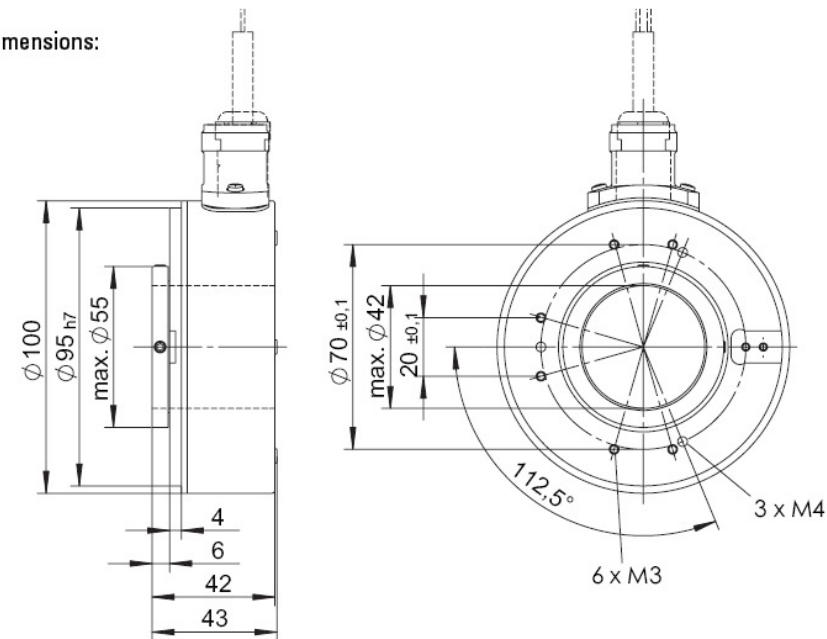

A Plug version

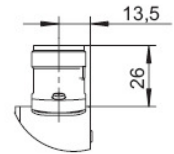

B Cable version

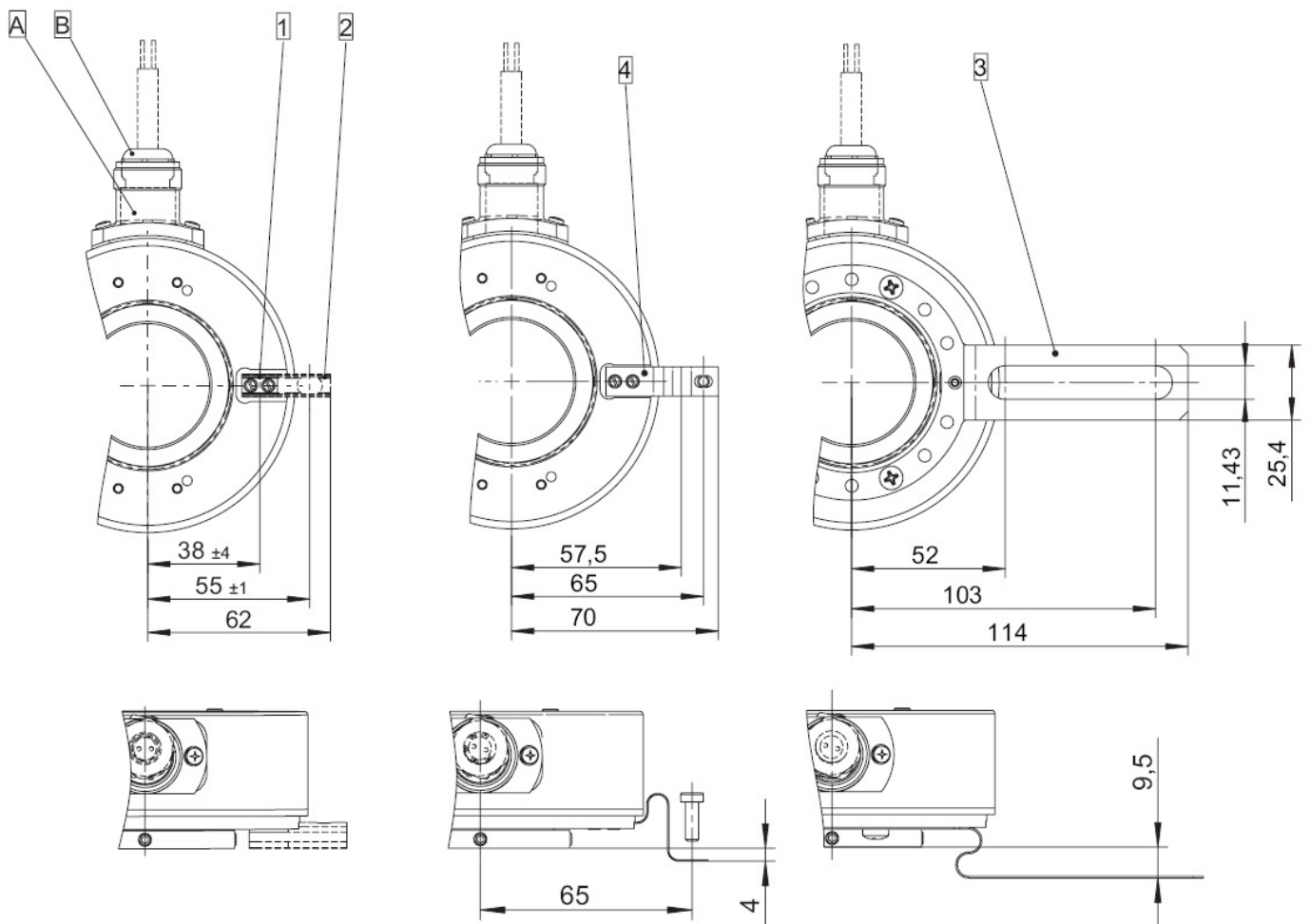
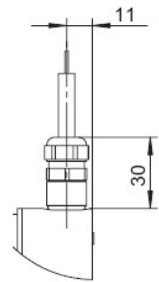

- 1 Spring element short (Bracket Nr. 2)
- 2 Spring element long (Bracket Nr. 3)
- 3 Tether arm long
- 4 Bracket

Note: minimum insertion depth $1,5 \times D_{\text{hollow shaft}}$

Large Diameter ENI 100

Terminal assignment:

Sig.:	0 V	0 V Sens ²⁾	+U _B	+U _B Sens ²⁾	A	\bar{A}	B	\bar{B}	0	$\bar{0}$	
Pin:	10	11	12	2	5	6	8	1	3	4	PH ¹⁾
Col.:	WH	GY PK	BN	RD BU	GN	YE	GY	PK	BU	RD	

1) PH = Shield is attached to connector housing

2) Sensor cables are connected to the supply voltage internally if long feeder cables are involved they can be used to adjust or control the voltage at the encoder. If the sensor cables are not in use, they have to be insulated or 0V_{Sensor} has to be connected to 0 V and U_{BSENSOR} has to be connected to U_B.

Using RS 422 outputs and long cable distances, a wave impedance has to be applied at each cable end. Insulate unused outputs before initial startup.

Order code:

ENI 100.XXXX.XXXX

Range

Bracket

- 1 = without mounting aid
- 2 = with short spring device
- 3 = with long spring device
- 4 = with mounting bracket short
- 5 = with mounting bracket long

Hollow shaft

- 1 = \varnothing 42 mm
- 2 = \varnothing 38 mm
- 3 = \varnothing 28 mm
- 4 = \varnothing 25.4 mm (1")
- 5 = \varnothing 25 mm
- 6 = \varnothing 24 mm
- A = \varnothing 30 mm**
- B = \varnothing 40 mm
- C = \varnothing 20 mm
- H = \varnothing 35 mm
- M = \varnothing 19 mm

Preferred types are indicated in bold

Pulse rate

(e.g. 360 pulses => 0360)

Type of connection

- 1 = Cable radial (1 m PVC-cable)
- 2 = radial 12 pin plug without mating connector

Output circuit and voltage display

- 1 = **RS 422 (with inverted signal)**
5 V supply voltage
- 2 = Push-pull (without inverted signal)
10 ... 30 V supply voltage
- 3 = **Push-pull (with inverted signal)**
10 ... 30 V supply voltage
- 4 = RS 422 (with inverted signal)
10 ... 30 V supply voltage
- 5 = Push pull (with inverted signal)
5 ... 30 V supply voltage
- A = Line driver 7272
5 ... 30 V supply voltage