

Rotary Measuring Technology

Absolute hollow shaft encoder, Multiturn, CANopen/CANlift

MICRONOR
automation components

Absolute, Multiturn ENFX 58 , CANopen/CANlift



Mechanical drive



Safety-Lock™



High rotational speed



Temperature -40° +80°



High IP



High shaft load capacity



Shock/vibration resistant



Magnetic field proof



Short-circuit proof



Reverse polarity protection

Reliable

- **Increased resistance against vibrations and installation mistakes. Avoids machine stops and repair work**
Sturdy "Safety-Lock™ Design" bearing structure
- **Few components and connection points increase the operational reliability**
OptoASIC technology with highest integration density (Chip-on-Board)
- **Remains tight, even in roughest environments, ensures highest safety against field breakdowns**
Resistant die cast housing and protection up to IP 67
- **Can be used in a wide temperature range without additional charge**
wide temperature range (-40°C...+80°C)
- **Failure-free operation immediately visible on the bus**



Fast

- **Really synchronous position acquisition of several axes**
Extended CAN Sync Mode with real-time position acquisition
- **Fast data availability while reducing the load on the bus and the control**
Intelligent functions like the transmission of speed, acceleration or exiting a working area
- **Fast, simple and error-free connection**

Versatile

- **Latest field bus performance for the applications**
CANopen, CANlift with the latest profiles
- **The suitable connection variant for every specific case**
Bus terminal cover with M12 connector or cable connection or fixed connection with M12, M23 or D-Sub connector, also easy point-to-point connections
- **Direct mounting also on large diameter standard shafts**
Blind hollow shaft up to 15 mm
- **The Bus is only used when this is really necessary - the user decides**
Event, Cyclic or Remote Mode
- **No wait times during machine start**
Starting directly possible in operational mode
- **Referencing without time loss**
Dynamic setting of a preset position during operation.

Mechanical characteristics:

Max. speed without shaft sealing (IP 65) up to 70 °C:	9 000 min ⁻¹ , continuous 7 000 min ⁻¹
Max. speed without shaft sealing (IP 65) up to T _{max} :	7 000 min ⁻¹ , continuous 4 000 min ⁻¹
Max. speed with shaft sealing (IP 67) up to 70 °C:	8 000 min ⁻¹ , continuous 6 000 min ⁻¹
Max. speed with shaft sealing (IP 67) up to T _{max} :	6 000 min ⁻¹ , continuous 3 000 min ⁻¹
Starting torque without shaft sealing (IP65):	< 0.01 Nm
Starting torque with shaft sealing (IP67):	< 0.03 Nm
Moment of inertia:	7.5 x 10 ⁻⁶ kgm ²
Weight:	appr. 0.57 kg with bus terminal cover appr. 0.52 kg with fixed connection
Protection acc. to EN 60 529:	housing: IP 67, shaft: IP 65, opt. IP 67
Working temperature:	-40° C ... +80 °C ¹⁾
Materials:	Hollow shaft: stainless steel, Flange: aluminium, Housing: die cast zinc , Cable: PVC
Shock resistance acc. to DIN-IEC 68-2-27:	>1000 m/s ² , 6 ms
Vibration resistance acc. to DIN-IEC 68-2-6:	>100 m/s ² , 55 ... 2000 Hz

¹⁾cable versions: -30 °C ... + 75 °C



- Absolutely safe operation even in strong magnetic fields
- Over 40 years of experience in the field of precision mechanics
- Special gears with specific toothing

Absolute, Multiturn ENFX 58 , CANopen/CANlift

General electrical characteristics:

Supply voltage:	10 ... 30 V DC
Current consumption (w/o output load):	24 V DC, max. 65 mA
Reverse polarity protection at power supply (U _b):	Yes
Conform to CE requirements acc. to EN 61000-6-1, EN 61000-6-4 and EN 61000-6-3	

Interface characteristics CANopen/CANlift:

Singleturn resolution (max, scaleable):	1 ... 65536 (16 bits), default scale value is set to 8192 (13 bits)
Total resolution:	28 Bit (scaleable 1 ... 2 ²⁸ steps)
Code:	Binary
Interface:	CAN High-Speed according ISO 11898, Basic- and Full-CAN CAN Specification 2.0 B
Protocol:	CANopen profile DS 406 V3.1 with manufacturer-specific add-on's

General information about CAN/CANlift

The CANopen encoders of the ENFX 58 support the latest CANopen communication profile according to DS 301 V4.02. In addition, device-specific profiles like the encoder profile DS 406 V3.1 and the profile DS 417 V1.1 (for lift applications) are available. The following operating modes may be selected: Polled Mode, Cyclic Mode, Sync Mode and a High Resolution Sync Protocol. Moreover, scale factors, preset values, limit switch values and many other additional parameters can be programmed via the CAN-Bus. When switching the device on, all parameters, which have been saved on an EEPROM to protect them against power failure, are loaded again.

The following output values may be combined in a freely variable way as PDO (PDO mapping): **position, speed, acceleration**, as well

CANopen Communication Profile V4.02

Among others, the following functionality is integrated:
Class C2 Functionality
NMT Slave • Heartbeat Protocol • High Resolution Sync Protocol
Identity Object • Error Behaviour Object • Variables PDO Mapping self-start programmable (Power on to operational)
3 Sending PDO's • 1 Receiving PDO for synchronous preset operation with minimal jitter • Knot address, baud rate and CANbus Programmable termination

CANopen Encoder Profile V3.1

The following parameters can be programmed:

- Event mode
- Units for speed selectable (Steps/Sec or RPM)
- Factor for speed calculation (e.g. measuring wheel periphery)
- Integration time for speed value of 1...32
- 2 work areas with 2 upper and lower limits and the corresponding output states
- Variable PDO mapping for position, speed, acceleration, work area status
- Extended failure management for position sensing with integrated temperature control
- User interface with visual display of bus and failure status - 3 LED's
- optional - 32 CAM's programmable
- Customer-specific memory - 16 Bytes

SET control button (zero or defined value, option)

Protected against accidental activation, can only be pushed in with the tip of a ball pen or similar.

Diagnostic LED (yellow)

LED on at:
optical sensor path faulty (code error, LED error), low voltage and overtemperature

	or CANlift profile DS 417 V1.1
Baud rate:	10 ... 1000 kbits/s (set by DIP switches/software configurable)
Node address:	1 ... 127 (set by rotary switches / software configurable)
Termination switchable:	Set by DIP switches Software configurable

as the status of the working area.

As a price-effective variant, encoders with a connector or a cable connection are available, for which the device address and baud rate are modified by means of software. The models with bus terminal cover and integrated T-shaped coupler allow a particularly easy installation: bus and power supply are connected very simply thanks to M12 connectors; the device address is set by means of two hexadecimal rotary switches. Furthermore, another DIP switch allows setting the baud rate and switching on a termination resistor. Three LED's located on the back indicate the operating or fault status of the CAN bus, as well as the status of an internal diagnostic.

CANopen Lift Profile DS 417 V1.1

Among others, the following functionality is integrated:

- Car Position Unit
- 2 virtual devices
- 1 virtual device delivers the position in absolute measuring steps (steps)
- 1 virtual device delivers the position as an absolute travel information in mm
- Lift number programmable
- Independent setting of the knot address in relation with the CAN identifier
- Factor for speed calculation (e.g. measuring wheel periphery)
- Integration time for speed value of 1...32
- 2 work areas with 2 upper and lower limits and the corresponding output states
- Variable PDO mapping for position, speed, acceleration, work area status
- Extended failure management for position sensing with integrated temperature control
- User interface with visual display of bus and failure status - 3 LED's

All profiles stated here: **Key-features**

The object 6003h "Preset" is assigned to an integrated key, accessible from the outside "Watchdog-controlled" device

Rotary Measuring Technology

Absolute hollow shaft encoder, Multiturn, CANopen/CANlift

Absolute, Multiturn ENFX 58 , CANopen/CANlift

With removable bus terminal cover

ø 58 mm, Flange with long torque stop
Flange type 1 and 2 (Drawing with 2x M12 connector)

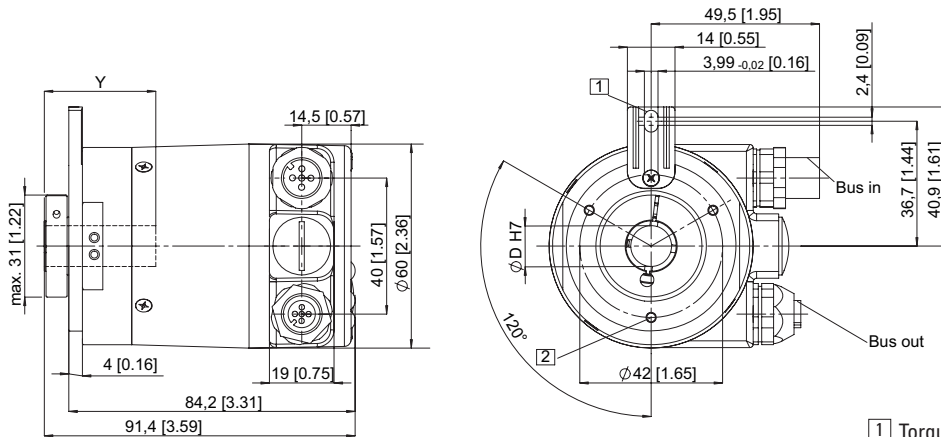

- 1 Torque stop slot,
Recommendation: cyl. pin. acc. DIN 7 Ø4
- 2 3xM3, 5.5 [0.21]deep

ø 58 mm, Flange with stator coupling
Flange type 5 and 6, pitch circle ø 63 mm (Drawing with cable versions)

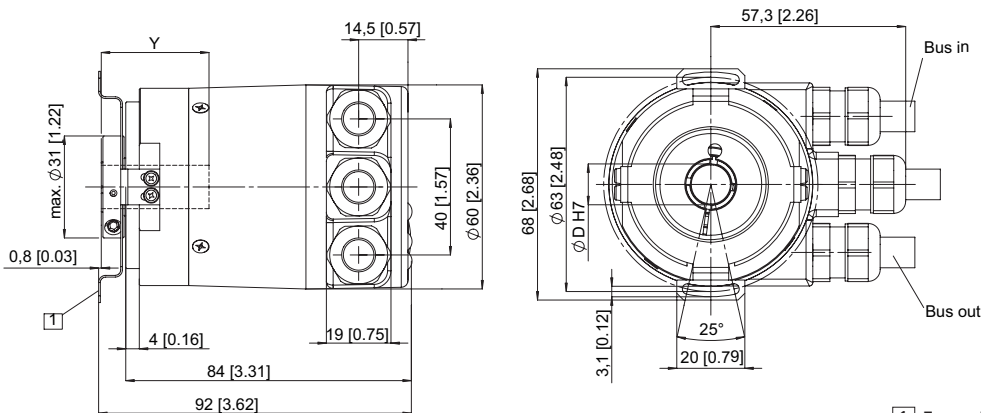

- 1 Fastening screw DIN 912 M3 x 8,
washer included

ø 58 mm, Flange with stator coupling
Flange type 3 and 4, pitch circle ø 65 mm (Drawing with 2x M12 connector)

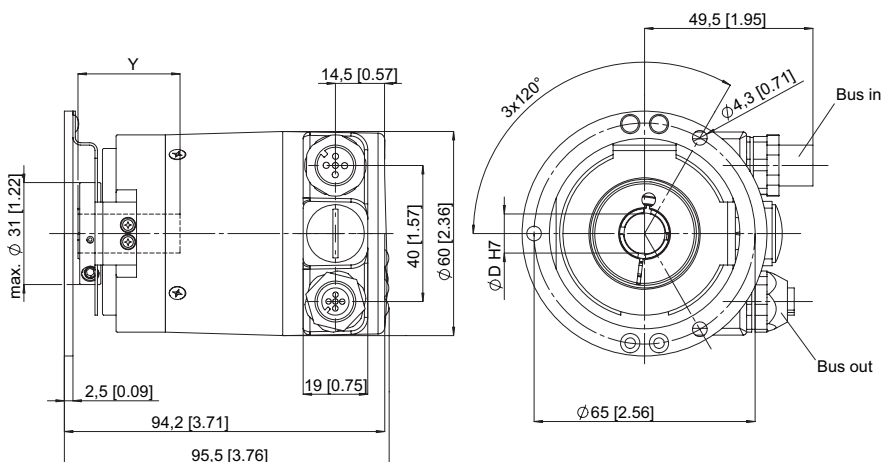

Y: Depth for blind
hollow shaft: 30 mm

Rotary Measuring Technology

Absolute hollow shaft encoder, Multiturn, CANopen/CANlift

Absolute, Multiturn ENFX 58 , CANopen/CANlift

With fixed connection

ø 58 mm, Flange with long torque stop
Flange type 1 and 2 (Drawing with M23 connector)

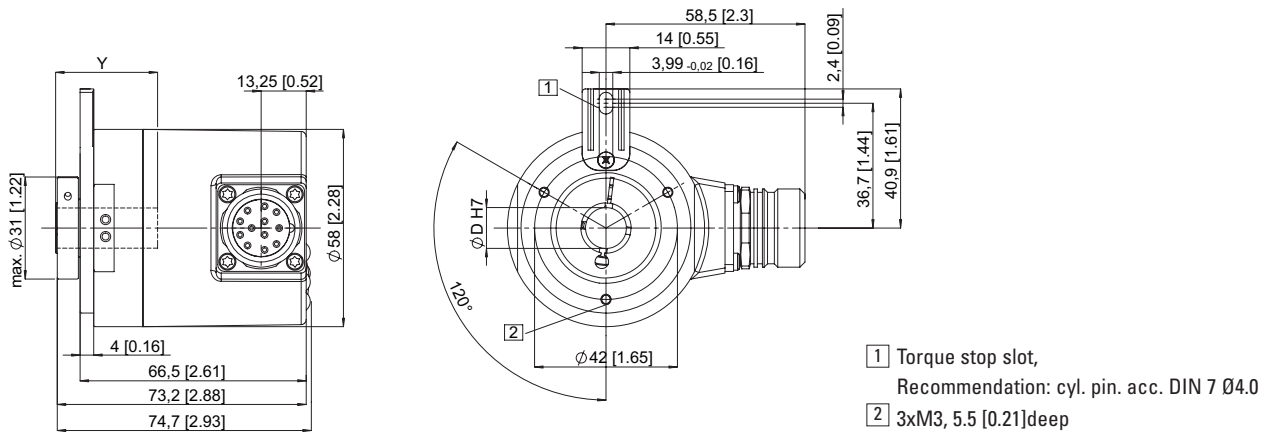

ø 58 mm, Flange with long torque stop
Flange type 1 and 2 (Drawing with D-SUB connector)

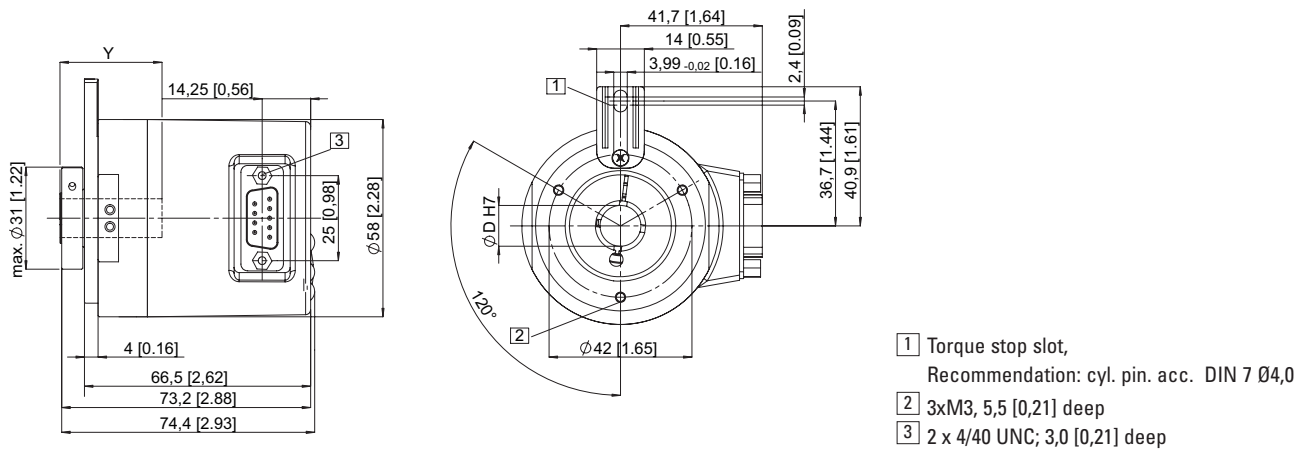

ø 58 mm, Flange with stator coupling
Flange type 3 and 4, pitch circle ø 65 mm (Drawing with 2xM23 connector)

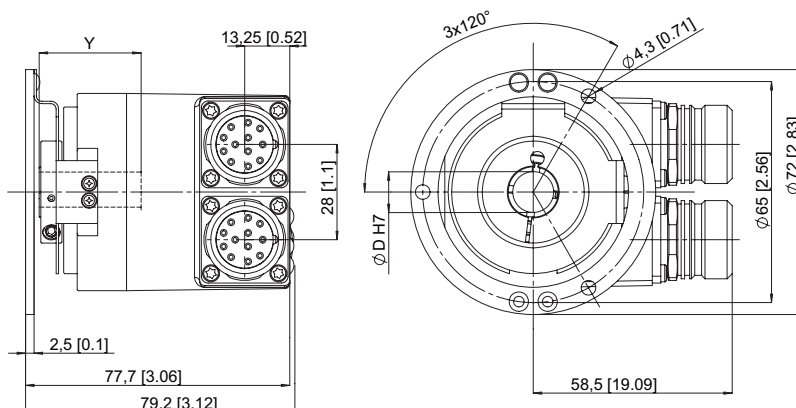

Rotary Measuring Technology

Absolute hollow shaft encoder, Multiturn, CANopen/CANlift

Absolute, Multiturn ENFX 58 , CANopen/CANlift

With fixed connection

ø 58 mm, Flange with stator coupling
Flange type 5 and 6, pitch circle ø 63 mm (Drawing with M12 connector)

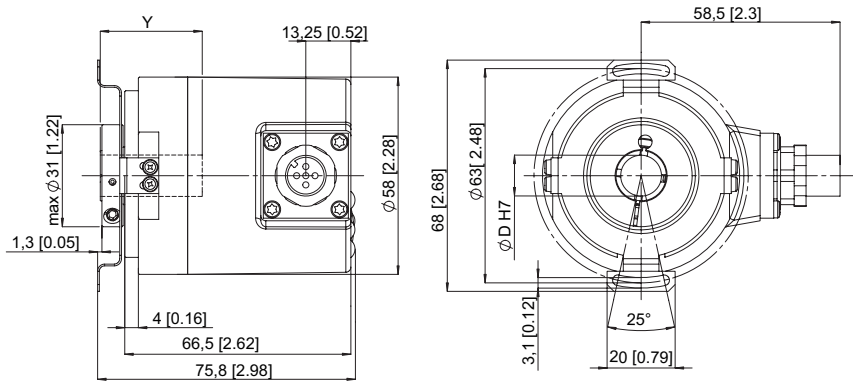

Y: Depth for blind hollow shaft: 30 mm

ø 58 mm, Flange with long torque stop
Flange type 1 and 2 (Drawing with 2xM12 connector)

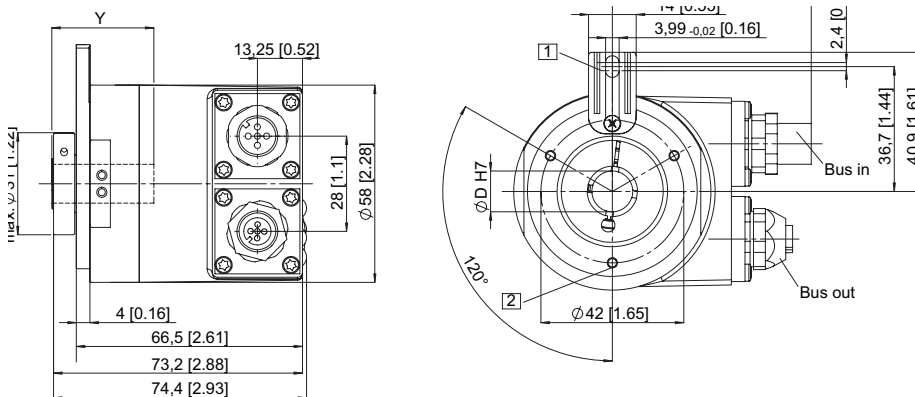

- 1 Torque stop slot,
Recommendation: cyl. pin. acc. DIN 7 Ø4.0
- 2 3xM3, 5.5 [0.21]deep

ø 58 mm, Flange with stator coupling
Flange type 3 and 4, pitch circle ø 65 mm (Drawing with 2x M12 connector)

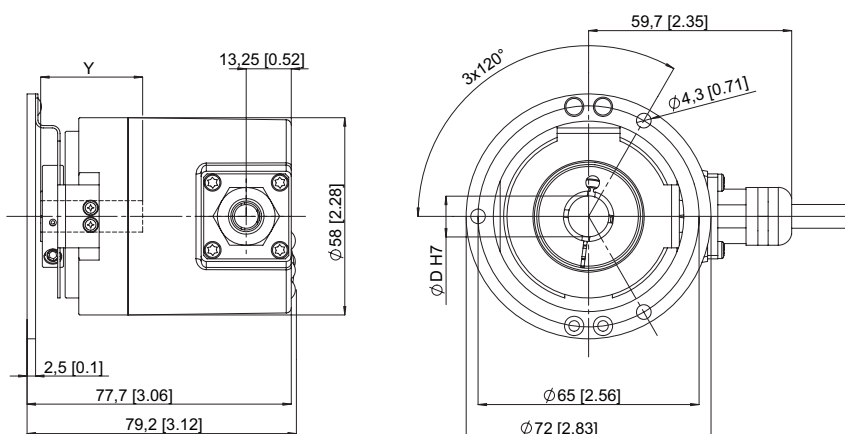

Y: Depth for blind hollow shaft: 30 mm

Absolute, Multiturn ENFX 58 , CANopen/CANlift

Terminal assignment:

Bus terminal cover with terminal box (type of connection 1)

Direction:	OUT					IN				
Signal:	CAN Ground	CAN_Low (-)	CAN_High (+)	0 Volt power supply	+UB power supply	0 V power supply	+UB power supply	CAN_Low (-)	CAN_High (+)	CAN Ground
Abbreviation:	CG	CL	CH	0 V	+V	0 V	+V	CL	CH	CG

Terminal assignment:

Cable connection (type of connection A) and D-SUB-9 connector (type of connection K)

Direction:	IN				
Signal:	0 V power supply	+UB power supply	CAN_Low (-)	CAN_High (+)	CAN Ground
Abbreviation:	0 V	+V	CL	CH	CG
Cable color:	BK	RD	BL	WH	GY
D-SUB 9	6	9	2	7	3

Terminal assignment:

Bus terminal cover with 2 x M12 connector (type of connection 2, F or J)

Direction:	OUT					IN				
Signal:	CAN Ground	CAN_Low (-)	CAN_High (+)	0 Volt power supply	+UB power supply	0 V power supply	+UB power supply	CAN_Low (-)	CAN_High (+)	CAN Ground
Abbreviation:	CG	CL	CH	0 V	+V	0 V	+V	CL	CH	CG
M23 PIN assignment	3	2	7	10	12	10	12	2	7	3
M12 PIN assignment	1	5	4	3	2	3	2	5	4	1

Bus in and out M23:

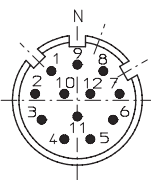

Bus out:



Bus in:

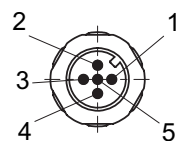

Terminal assignment:

M23 (type of connection I) or M12 (type of connection E) connector

Richtung:	IN				
Signal:	0 V power supply	+UB power supply	CAN_Low (-)	CAN_High (+)	CAN Ground
Abbreviation:	0 V	+V	CL	CH	CG
M23 PIN assignment	10	12	2	7	3
M12 PIN assignment	3	2	5	4	1

Bus in M23:

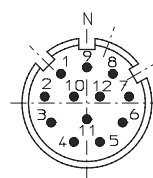

Bus in M12:

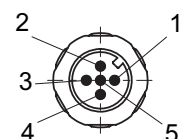

Absolute, Multiturn ENFX 58 , CANopen/CANlift

Order code:

ENFX 58 . X X X X . X X 1 X

Type

Flange

- 1 = Flange with torque stop IP 65
- 2 = Flange with torque stop IP 67
- 3 = Flange with stator coupling pitch circle ø 65, IP 65
- 4 = Flange with stator coupling pitch circle ø 65, IP 67
- 5 = Flange with stator coupling pitch circle ø 63, IP 65**
- 6 = Flange with stator coupling pitch circle ø 63, IP 67

Hollow shaft

- 3 = Blind hollow shaft ø 10 mm
- 4 = Blind hollow shaft ø 12 mm**
- 5 = Blind hollow shaft ø 14 mm
- 6 = Blind hollow shaft ø 15 mm
- 8 = Blind hollow shaft ø 9,52 mm [3/8"]
- 9 = Blind hollow shaft ø 12,7 mm [1/2"]

Output circuit / Power supply

- 2 = CANopen DS 301 V4.0**
- 10 ... 30 V DC**

Ex-proof zone 2, 22 on request

*Preferred types are indicated in **bold***

Options (service)

- 2 = no option
- 3 = SET button**

Field bus profile³⁾

- 21 = CANopen Encoder-Profile DS 406 V3.1**
- 22 = CANlift DS 417 V1.01

Type of connection

- 1 = With removable bus terminal cover, with radial screwed cable passage
- 2 = Removable bus terminal cover with 2 x M12 connector**
- A = Fixed connection without bus terminal cover, with radial cable (2 m PVC)
- E = Fixed connection without bus terminal cover, with 1 x M12 radial connector
- F = Fixed connection without bus terminal cover, with 2 x M12 radial connector
- I = Fixed connection without bus terminal cover, with 1 x M23 radial connector
- J = Fixed connection without bus terminal cover, with 2 x M23 radial connector
- K = Fixed connection without bus terminal cover, with 1 x D-SUB 9-pin connector

³⁾ CAN parameters can also be factory-preset