

Rotary Measuring Technology

Absolute hollow shaft encoder, Multiturn, SSI/BiSS

MICRONOR
automation components

Absolute, Multiturn ENAMX 58, SSI/BiSS

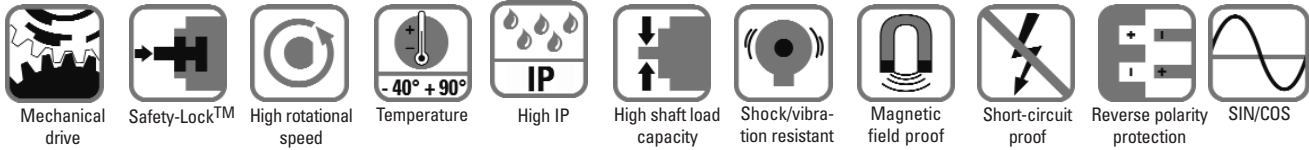

Reliable

- **Increased resistance against vibrations and installation mistakes. Avoids machine stops and repair work**
Sturdy "Safety-Lock™ Design" bearing structure
- **Few components and connection points increase the operational reliability**
OptoASIC technology with highest integration density (Chip-on-Board)
- **Remains tight, even in roughest environments, ensures highest safety against field breakdowns**
Resistant die cast housing and protection up to IP 67
- **Can be used in a wide temperature range without additional charge**
wide temperature range (-40°C...+90°C)
- **Easy diagnostic in case of trouble**
Status indication by means of LED, sensor, voltage and temperature monitoring.

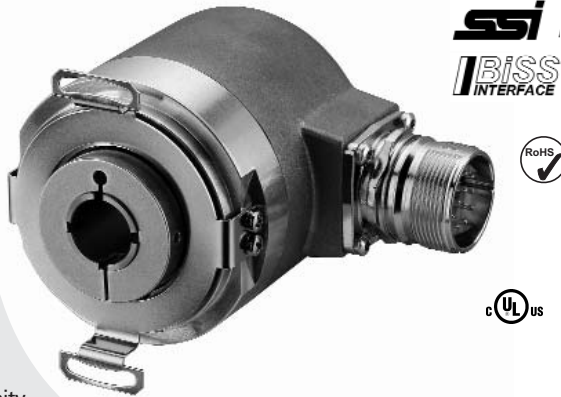

Fast

- **Can achieve particularly high accuracy in the applications**
Update rate of the whole position value above 100 kHz (real-time)
- **Allows high productivity thanks to very short regulation cycles**
Clock rate with SSI up to 2 MHz, with BiSS up to 10 MHz
- **High-resolution feedback system achievable in real-time**
SinCos incremental outputs.

Versatile

- **Direct mounting also on large diameter standard shafts**
Through hollow shaft up to 14 mm (15 mm with blind hole shaft)
- **The suitable connection variant for every specific case**
Cable, M23 connector or M12 connector
- **Open interfaces ensure flexibility and independence**
SSI or BiSS with Sine-Cosine-Option
- **Reliable mounting in the most various installation cases**
Comprehensive and proven mounting possibilities
- **Only the functionality really needed by the user is implemented**
Status LED and Set key available as options
- **Fast and comfortable start-up on site**
Set key or Preset by means of a control input.

Mechanical characteristics:

Max. speed without shaft sealing (IP 65) up to 70 °C:	6 000 min ⁻¹ , continuous 9 000 min ⁻¹
Max. speed without shaft sealing (IP 65) up to T _{max} :	3 000 min ⁻¹ , continuous 6 000 min ⁻¹
Max. speed with shaft sealing (IP 67) up to 70 °C:	4 000 min ⁻¹ , continuous 8 000 min ⁻¹
Max. speed with shaft sealing (IP 67) up to T _{max} :	2 000 min ⁻¹ , continuous 4 000 min ⁻¹
Starting torque without shaft sealing (IP65):	< 0.03 Nm
Starting torque with shaft sealing (IP67):	< 0,05 Nm
Moment of inertia:	7.0 x 10 ⁻⁶ kgm ²
Weight:	appr. 0.45 kg
Protection acc. to EN 60 529:	housing: IP 67, shaft: IP 65, opt. IP 67
Working temperature:	-40° C ... +90 °C ¹⁾
Materials:	Shaft: stainless steel, Flange: aluminium, Housing: die cast zinc, Cable: PVC
Shock resistance acc. to DIN-IEC 68-2-27:	>2500 m/s ² , 6 ms
Vibration resistance acc. to DIN-IEC 68-2-6:	>100 m/s ² , 55 ... 2000 Hz

¹⁾cable versions: -30 °C ... + 75 °C



- Absolutely safe operation even in strong magnetic fields
- Over 40 years of experience in the field of precision mechanics
- Special gears with specific toothing

Absolute, Multiturn ENAMX 58, SSI/BiSS

General electrical characteristics:

Supply voltage:	5 V DC \pm 5% or 10 ... 30 V DC
Current consumption (w/o output load):	5 V DC: max. 70 mA, 24 V DC: max. 20 mA
Reverse polarity protection at power supply (U _b):	Yes
Conforms to CE requirements acc. to EN 61000-6-1, EN 61000-6-4 and EN 61000-6-3	

General Interface characteristics:

Output driver:	RS 485 Transceiver type
Permissible load/channel:	max. \pm 20 mA
Signal level high:	typ. 3.8 V
Signal level low at I _{load} = 20 mA:	typ. 1.3 V
Short circuit proof outputs:	Yes ²⁾

Interface characteristics SSI:

Singleturn resolution:	10 ... 14 bits and 17 bits ³⁾
Code:	Binary or Gray
SSI clock rate:	\leq 14 bits: 50 kHz ... 2 MHz
Monoflop time:	\geq 15 μ s ³⁾
Note:	If clock starts cycling within monoflop time a second data transfer starts with the same data, useful for data verification. If clock starts cycling after monoflop time the data transfer starts with updated values. Max. update rate is depending on clock speed, data length and monoflop-time.
Time jitter (data request to position latch):	$<$ 1 μ s up to 14 bits, \leq 4 μ s at 15 ... 17 bits
Status and Parity bit:	optional on request

Interface characteristics BiSS:

Singleturn resolution:	10...14 bits and 17 bits, customer programmable ³⁾
Code:	Binary
Interfaces:	RS 485
Clock rate:	up to 10 MHz
Max. update rate:	$<$ 10 μ s, depending on clock speed and data length
Time jitter (data request to position latch):	\leq 1 μ s
Note:	– Bidirectional, programmable parameters are: resolution, code, direction, alarms and warnings – Multicycle data output, e.g. for temperature – CRC data verification

²⁾ Short circuit to 0V or to output, one channel at a time, supply voltage correctly applied

³⁾ Other options upon request

SET (zero or defined value) and DIRrection (CW/CCW) control inputs

Input characteristics:	High active
Receiver type:	Comparator
Signal level high:	min. 60 % of V ₊ (Supply voltage), max: V ₊
Signal level low:	max. 25% of V ₊ (Supply voltage)
Input current:	\leq 0.5 mA
Min. pulse duration (SET):	10 ms
Timeout after SET input:	14 ms
Reaction Time (DIR input):	1 ms

The encoder can be set to zero at any position by means of a HIGH signal on the SET input or by pressing the optional SET key. Other preset values can be factory-programmed. The SET input has a signal delay time of approx. 1 ms. Once the SET function has been triggered, the encoder requires an internal processing time of approx. 15 ms before the new position data can be read. During this time the LED is ON and the status output is at LOW.

Status output and LED

Output driver:	Open collector, internal pull up resistor 22 kOhm
Permissible load:	-20 mA
Signal level high:	+V
Signal level low:	$<$ 1 V
Active at:	Low
Note:	The optional LED (red) and the status output serve to display various alarm or error messages. In normal operation the LED is OFF and the status output is HIGH (open-collector with int. pull-up 22k). If the LED is ON (status output LOW) this indicates: – Sensor error, singleturn or multiturn (soiling, glass breakage etc.) – LED error, failure or ageing – Over- or under-temperature – Undervoltage In the SSI mode, the fault indication can only be reset by switching off the power-supply to the device.

DIR input

A HIGH signal switches the direction of rotation from the default CW to CCW. This inverted function can also be factory-programmed. If DIR is changed when the device is already switched on, then this will be interpreted as an error. The LED will come ON and the status output will switch to LOW.

Option incremental output (A/B), 2048 ppr

	Sin/Cos	RS422 (TTL compatible)
-3dB frequency:	400 kHz	400 kHz
Signal level:	1 V _{pp} (\pm 20%)	high: min. 2.5 V low: max. 0.5 V
Short circuit proof:	Yes ²⁾	Yes ²⁾

Power-on delay

After Power-ON the device requires a time of approx. 150 ms before valid data can be read.

Absolute, Multiturn ENAMX 58, SSI/BiSS

Flange with long torque stop

ø 58 mm, M12, M23 connector, cable versions
Flange type 1 and 2 (Drawing with M12 connector)

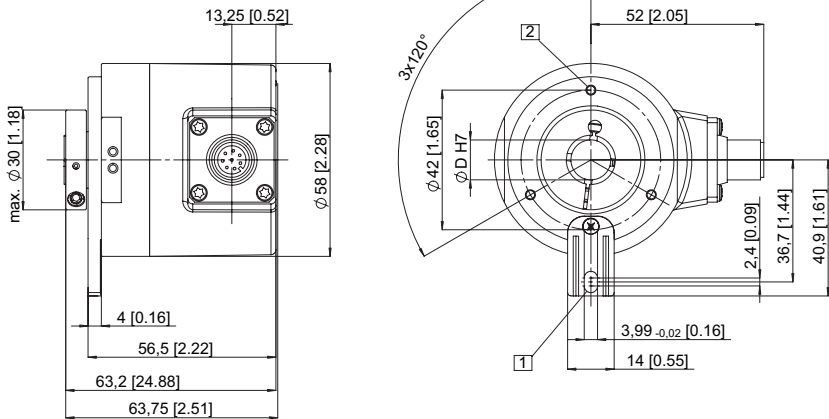

- 1 Torque stop slot,
Recommendation: cyl. pin. acc. DIN 7 Ø4
- 2 3xM3, 5.5 [0.21] deep

Flange with stator coupling

ø 58 mm, M12, M23 connector, cable versions
Flange type 5 and 6, pitch circle ø 63 mm (Drawing with M23 connector)

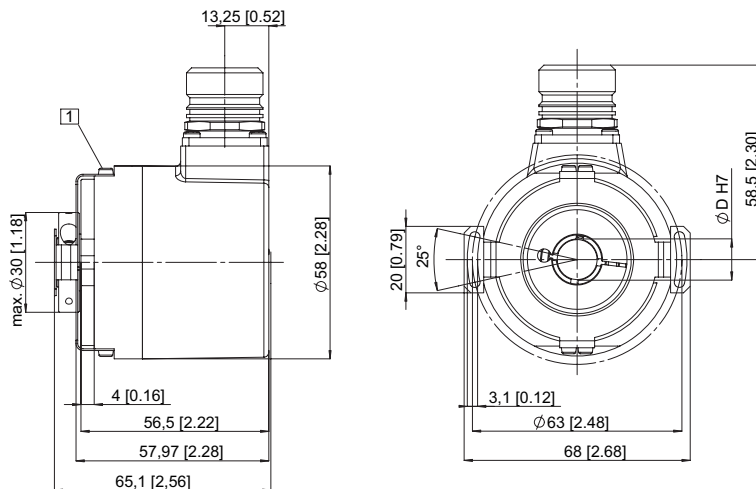

- 1 Fastening screw DIN 912 M3 x 8,
washer included

Flange with stator coupling

ø 58 mm, M12, M23 connector, cable versions
Flange type 3 and 4, pitch circle ø 65 mm (Drawing with cable version)

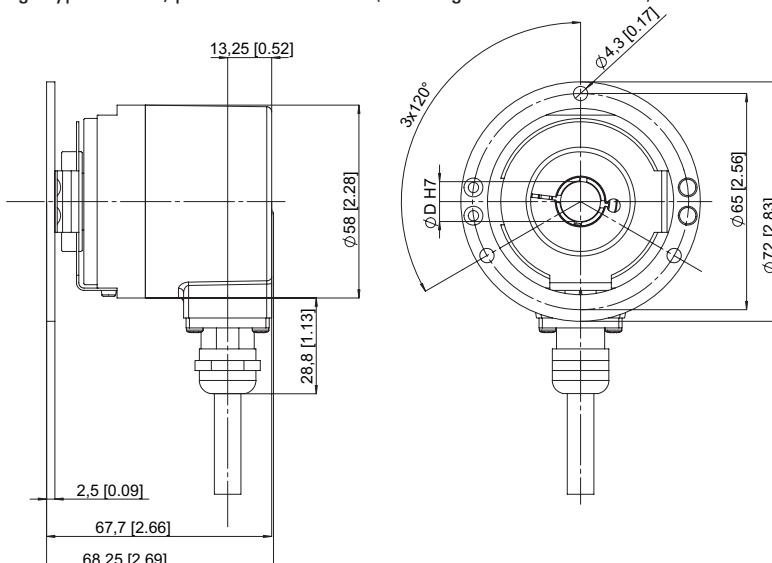

Absolute, Multiturn ENAMX 58, SSI/BiSS

Terminal assignment:

for output circuit 1 or 2 and type of connection 2 or 4 (2 control inputs, 1 status output)

Signal:	GND	+V	+C	-C	+D	-D	SET	DIR	Stat	N/C	N/C	N/C	PE
Cable color:	WH	BN	GN	YE	GY	PK	BU	RD	BK	-	-	-	Shield
M23 PIN out:	1	2	3	4	5	6	7	8	9	10	11	12	PH

for output circuit 5 and type of connection 2 or 4 (2 control inputs, 1 status output, voltage sense outputs)

Signal:	GND	+V	+C	-C	+D	-D	SET	DIR	Stat	N/C	0 V Sens	+Ub Sens	PE
Cable color:	WH	BN	GN	YE	GY	PK	BU	RD	BK	-	GY-PK	RD-BU	Shield
M23 PIN out:	1	2	3	4	5	6	7	8	9	10	11	12	PH

for output circuit 3, 4, 7 or 8 and type of connection 2 or 4 (2 control inputs, sine/cosine or incremental track)

Signal:	GND	+V	+C	-C	+D	-D	SET	DIR	A	A inv	B	B inv	PE
Cable color:	WH	BN	GN	YE	GY	PK	BU	RD	BK	VT	GY-PK	RD-BU	Shield
M23 PIN out:	1	2	3	4	5	6	7	8	9	10	11	12	PH

for output circuit 6 or 9 and type of connection 2 or 4 (Sine/cosine or incremental track, voltage sense outputs)

Signal:	GND	+V	+C	-C	+D	-D	A	A inv	B	B inv	0V Sens	+Ub Sens	PE
Cable color:	WH	BN	GN	YE	GY	PK	BU	RD	BK	VT	GY-PK	RD-BU	Shield
M23 PIN out:	1	2	3	4	5	6	7	8	9	10	11	12	PH

for output circuit 1 or 2 and type of connection 6 (2 control inputs)

Signal:	GND	+V	+C	-C	+D	-D	SET	DIR	Shield/PE
M12 PIN out:	1	2	3	4	5	6	7	8	PH

- | | | | |
|---------|--|----------|-----------------------------|
| +V: | Encoder Power Supply +V DC | Stat: | Status output |
| GND: | Encoder Power Supply Ground (0V) | PE: | Protective earth |
| +C, -C: | Clock signal | PH: | Plug housing (shield) |
| +D, -D: | Data signal | A, Ainv: | Sine output (incremental) |
| SET: | Set input. The current position becomes defined as position zero | B, Binv: | Cosine output (incremental) |
| DIR: | Direction input: If this input is active, output values are decreasing when shaft is turned clockwise. | | |

Absolute, Multiturn ENAMX 58, SSI/BiSS

Order code:

ENAMX 58. X X X X . X X X X

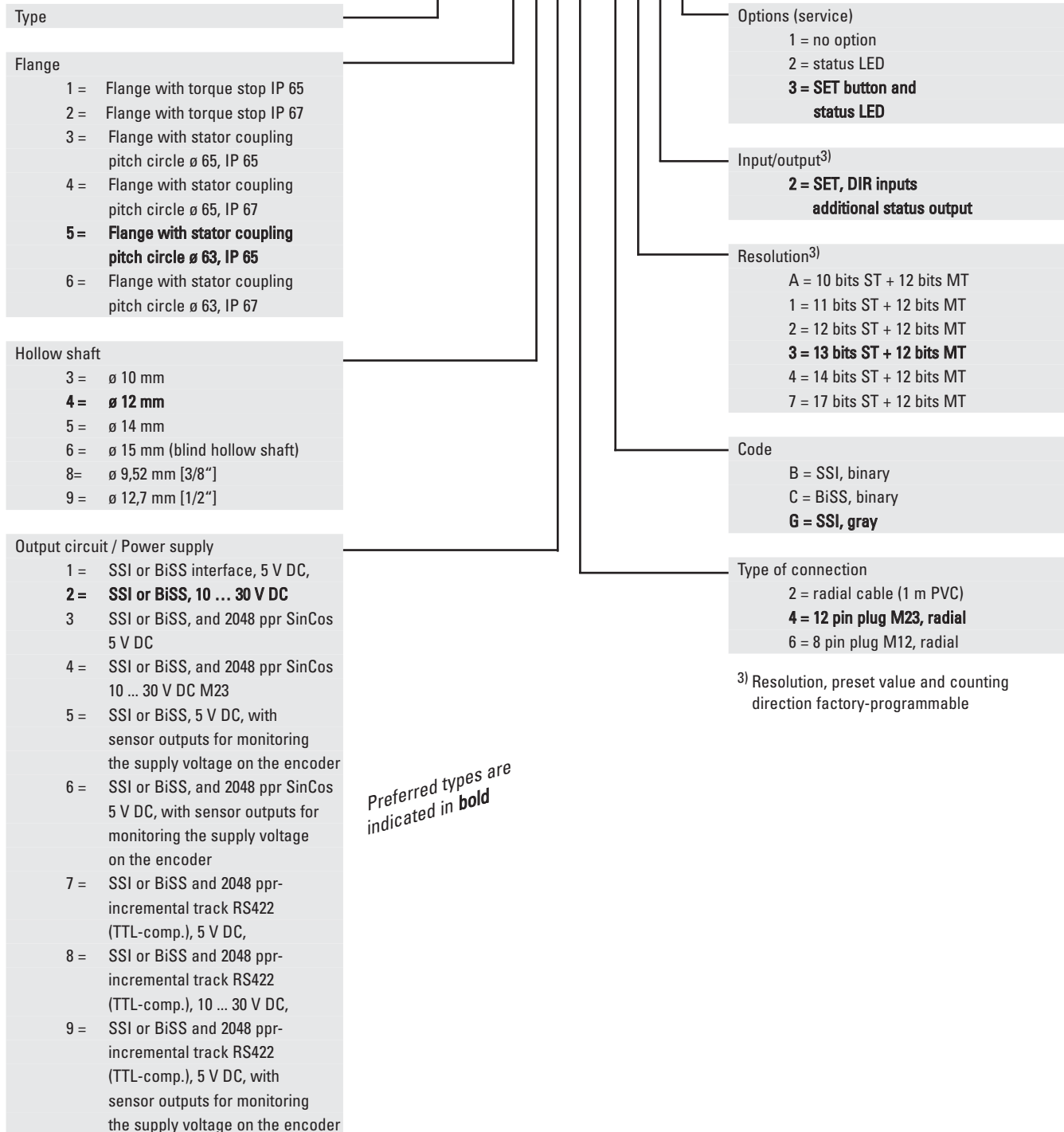

Ex-proof zone 2, 22 on request