

# Rotary Measuring Technology

## Absolute multiturn encoder hollow shaft version

### Multiturn ENAM 58S SSI Standard Line

- New price entry-level class for Absolute Multiturn Encoders
- Patented Intelligent Sensing Technology ensures high operational reliability. Ideal for dynamic applications thanks to its non-contact multiturn stage

Compact design due to Integrative Technology construction

Patented Intelligent Sensing Technology



Temperature and ageing compensation

Long service life in harsh operating environments; high shock and vibration resistance up to 250 g



#### Mechanical characteristics:

Speed: <sup>1)</sup>	max. 6 000 min <sup>-1</sup>
Rotor moment of inertia:	appr. 6 x 10 <sup>-6</sup> kgm <sup>2</sup>
Starting torque hollow shaft version:	< 0.05 Nm
Weight:	appr. 0.5 kg
Protection acc. to EN 60 529:	IP 65
Working temperature: <sup>2)</sup>	-20° C ... +70 °C
Operating temperature:	-20° C ... +80 °C
Shaft:	stainless steel
Shock resistance acc. to DIN-IEC 68-2-27	2500 m/s <sup>2</sup> , 6 ms
Vibration resistance acc. to DIN-IEC 68-2-6:	100 m/s <sup>2</sup> , 10 ... 2000 Hz

#### Product features:

- Resolution: up to 8192 (13 Bit) ppr, 4096 (12 Bit) ppr
- Housing ø 58 mm, only 66 mm deep
- Solid shaft ø 6 or ø 10 mm
- Protection IP 65
- SET and V/R input

<sup>1)</sup> For continuous operation 3000 min<sup>-1</sup>

<sup>2)</sup> Non-condensing

#### Electrical characteristics:

Interface type:	Synchronous-Serial (SSI)
<b>General information:</b>	
Supply voltage (U <sub>B</sub> ):	5.0 ... 30 V DC <sup>3)</sup>
Current consumption type (no load):	89 mA
max (no load):	138 mA
Short circuit proof outputs: <sup>1)</sup>	yes <sup>2)</sup>
Reverse connection protection at U <sub>B</sub> :	yes
<b>SSI-Interface:</b>	
Output driver:	RS 485
Permissible load/channel:	max. +/-20 mA
Update rate for position data:	appr. 1600/s
SSI pulse rate min./max./pulse frequency:	100 kHz/500 kHz
Signal level high:	typ. 3.8 V
Signal level low (I <sub>Last</sub> = 20 mA):	typ. 1.3 V
Rise time t <sub>r</sub> (without cable):	max. 100 ns
Fall time t <sub>f</sub> (without cable):	max. 100 ns
<b>Control inputs:</b>	
Voltage:	5 ... 30 V DC = U <sub>B</sub>
(V/R, SET) Response time:	10 ms
Signal level: low	max. 25% U <sub>B</sub>
high	min. 60% U <sub>B</sub> , max. U <sub>B</sub>
Max. current input	≤ 0,5 mA

<b>Status outputs:</b>	Output driver:	Push-Pull
Battery monitoring	max. permissible load:	±9.0 mA
	Signal level high:	min. U <sub>B</sub> - 3.0 V
	low:	max. 1.5 V
	Rise time:	max. 240 µs
	Fall time:	max. 300 µs

Conforms to CE requirements acc. to EN 61000-6-1, EN 61000-6-4 and EN 61000-6-3 Performance against magnetic influence acc. to EN61000-4, 5

<sup>1)</sup> If U<sub>B</sub> supply voltage correctly applied U<sub>B</sub>

<sup>2)</sup> Only one channel allowed to be shorted out:  
If U<sub>B</sub> = 5 V DC, short-circuit to output, 0 V and + U<sub>B</sub> is permitted.  
If U<sub>B</sub> < 5 V DC short-circuit to output and 0 V is permitted.

<sup>3)</sup> The supply voltage at the encoder input must not be less than 4.75 V (5 V - 5%)

### Multiturn ENAM 58S SSI standard line

#### Control inputs:

##### F/R input for change of direction:

The encoder can output increasing code values when the shaft is rotated either clockwise or counter-clockwise (when looking from the shaft side).  
This option must be selected before the operating voltage is supplied.

Hardware configuration of the F/R input	Function:
"low" (0V) on the F/R input (=cw) (advantage position setting through internal pull-down resistor)	cw
"high" (+UB ) on the F/R input (= ccw)	ccw

#### Notes:

- If the direction of rotation is changed due to the F/R configuration, without activating the SET function again, and if the encoder is also then powered up again, a new position value may be outputted, even if the physical shaft position of the encoder has not moved! This is due to internal conversion processes.

The start-up procedure for the encoder should therefore follow this sequence:

1. Determine the count direction of the encoder either via the F/R input or via programming
  2. Apply power to the encoder
  3. Activate the SET function, if desired (see SET input below)
- If using a cable wire to configure the F/R input, then for EMC reasons the wire should not remain open but should be tied either to 0V or UB!

#### SET input:

This input is used for a alignment (zeroing) of the encoder. A high control pulse (+UB) applied to this input will reset the current encoder position to zero.

#### Notes:

- The SET function should only be implemented when the encoder shaft is at rest.
- For the duration of the SET pulse the SSI interface does not function and therefore does not output any valid position values! In order to avoid malfunctions, no SSI clock pulse should occur during the SET pulse.

- If a cable wire is used to configure the SET input, then for EMC reasons the wire should not remain open but should if at all possible be tied to 0 V, as soon as no SET pulse is triggered!

#### Terminal assignment:

Signal :	0V	+UB	+T	-T	+D	-D	ST	VR	A1	PH
Pin	1	2	3	4	5	6	7 <sup>1)</sup>	8	9	
Col.:	WH	BN	GN	YE	GY	PK	BU	RD	BK	

T: Clock signal  
D: Data signal  
ST: SET input. The current position value is stored as new zero position (or the actual value is set to the preset

VR: value when using the programmable version).  
Up/down input. As long as this input is active, decreasing code values are transmitted when shaft turning clockwise.  
PH: Plug housing  
Insulate unused outputs before initial start-up

Top view of mating side, male contact base: 12 pin plug

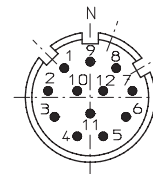

#### Patented Integrative Technology :

Integrative Technology, developed and patented, is a package of measures that ensures compact construction, high signal quality, high shock resistance - up to 2500 m/s<sup>2</sup>, high reliability and a high level of immunity to EMC.

This is achieved using an Opto ASIC, a multilayer board and an especially shock resistant and space-saving method of mounting the sensor unit. In addition the use of a highly optimized interface ASIC ensures the integration of several hundred individual components. Components that had previously been needed to balance the system, such as balancing potentiometers, can be dispensed with.

#### Patented Intelligent-Sensing-Technology

An innovative principle of operation based on a non-contact electronic multiturn stage overcomes system disadvantages previously associated with encoders that had mechanical gears or with traditional electronic gear technology.

#### Advantages:

- High operational reliability
- Logic filter and innovative principle of operation compensate for high EMC interference
- Free from wear

**Multiturn ENAM 58S SSI Standard Line**

**Dimensions:**

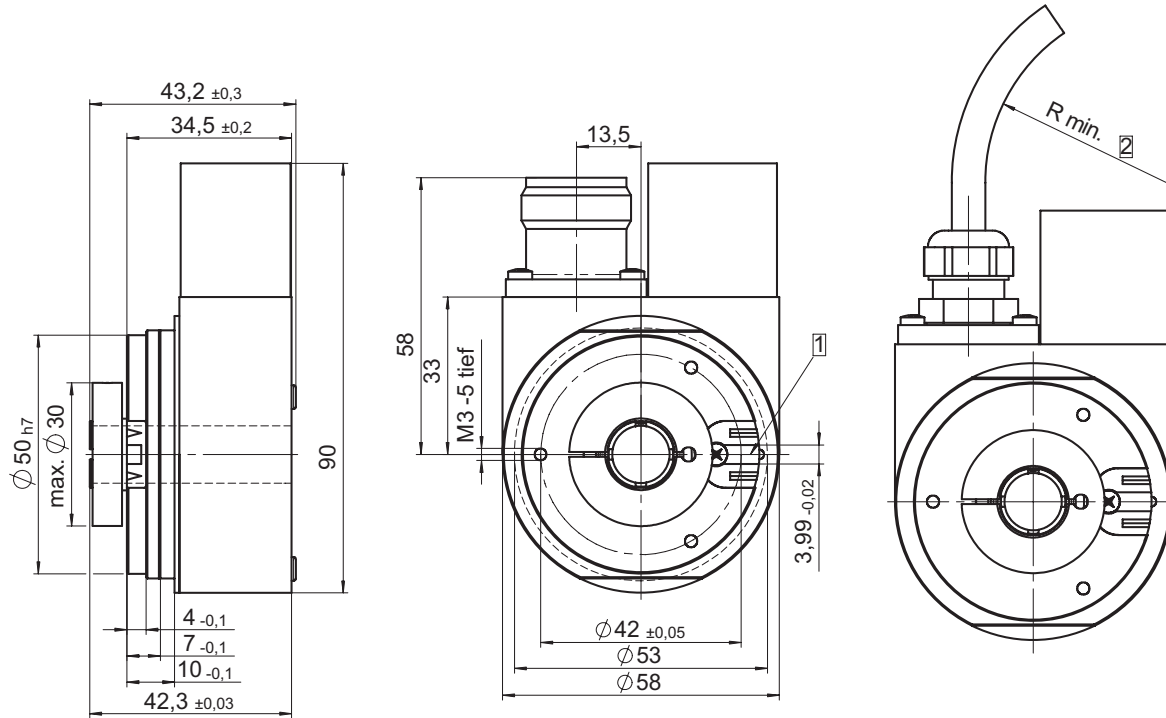

- 1 torque stop slot  
 Recommendation: Cyl. pin. acc. to DIN 7-04
- 2 Cable,  
 – securely installed: 55 mm  
 – flexibility installed: 70 mm

**Order code:**

**ENAM 58S.XXXX.XXXX**

