

**MR267**  
**Current Loop Control**  
**(CLC) Option**  
**for**  
**Motorized Potentiometers**

Doc No: MR267-135  
Rev: A2: 10-28-2005

MICRONOR AG  
Pumpwerkstrasse 32  
CH-8105 Regensdorf  
Switzerland  
PH: +41 44 843 40 20  
FX: +41 44 843 40 39  
sales@micronor.ch  
[www.micronor.ch](http://www.micronor.ch)

**Notice of Proprietary Rights**

The design concepts and engineering details embodied in this manual, which are the property of MICRONOR AG, are to be maintained in strict confidence; no element or detail of this manual is to be spuriously used, nor disclosed, without the express written permission of MICRONOR AG. All rights are reserved. No part of this publication may be reproduced, stored in a retrieval system, or transmitted in any form or by any means, electronic, mechanical, photocopying, recording, or otherwise, without prior written permission from MICRONOR AG.

© COPYRIGHT 2005, MICRONOR AG  
Pumpwerkstrasse 32, Regensdorf  
Switzerland

## Revision History

Rev A	Initial Release
Rev A1	Update to Specifications Correction to Trimpot Adjustment procedures Added MP-Series Motor Pots and DPX-Series Potentiometer data sheets to Reference Document section
Rev A2	Additions to Section 1 – Product Description Minor corrections to Section 3 – Specifications German translation based on this revision

## Table of Contents

<b>Revision History</b> .....	2
<b>1. Product Description</b> .....	5
1.1 Motor Pot Background .....	5
1.2 MR267 Current Loop Control (CLC) Option .....	5
<b>2. Warranty Information</b> .....	7
2.1 Limitations of Warranty .....	7
2.2 Contact Information .....	7
<b>3. Specifications</b> .....	8
<b>4. Initial Preparation</b> .....	9
4.1 Unpacking and Inspection .....	9
4.2 Damage in Shipment .....	9
4.3 Standard Contents .....	9
<b>5. Installation Guidelines</b> .....	10
5.1 Mounting the Motor Pot .....	10
5.2 Wiring Options and Connections To The MR267 Control Board .....	10
5.3 Selecting and Wiring MR267 Mode of Operation .....	12
5.4 Setting SPEED and POSITION Trimpot Settings on MR267 CLC Board .....	13
5.5 Wiring to USER Potentiometer(s) .....	15
5.6 Cam Programming and Limit Switch Wiring .....	15
5.7 First Time Start-Up and Performance Verification .....	18
<b>6. Maintenance and Service</b> .....	19
6.1 Replacing Microswitches .....	19
<b>7. Reference Documents</b> .....	20
MICRONOR 9200.00.047 MPP-Style Motor Pot With MR267 4-20mA Control Option (Reference Drawing) .....	21
MICRONOR MPP Series 1-Turn Motor Pot (DIN Rail Side Mount) Data Sheet .....	22
MICRONOR MPR Series 1-Turn Motor Pot (DIN Rail End Mount) Data Sheet .....	23
MICRONOR MP Series Custom 1-Turn Motor Pot (DIN Rail Side Mount) Data Sheet .....	24
MICRONOR MPZ Series 10-Turn Motor Pot (DIN Rail Side Mount) Data Sheet .....	25
MICRONOR MPRZ Series 10-Turn Motor Pot (DIN Rail End Mount) Data Sheet .....	26
MICRONOR DPC Series 1-Turn 5W Wirewound Potentiometer Data Sheet .....	27
MICRONOR DPM Series 1-Turn High Wattage (20-60-170W) Wirewound Potentiometers Data Sheet .....	28

**MICRONOR DPZ Series Precision 10-Turn 2W Wirewound Potentiometers Data Sheet**  
.....29

## List of Figures

Figure 1. Micronor Motor Pot With Installed MR267 CLC Option.....	6
Figure 2. Direct and DIN Rail Mounting Options for Motor Pots. ....	10
Figure 3. Wiring Reference For MR267 CLC Board.....	11
Figure 4. Making Connections To The WAGO Wiring Strip (J1). ....	13
Figure 5. Photograph of Motor Pot Set to '0' Position. ....	14
Figure 6. Wiring Diagram For DPC Series USER Potentiometers. ....	15
Figure 7. Examples of Cam Programming and Switch Response. ....	16
Figure 8. Photograph Showing KS25B4 and S84 Microswitches.....	19

## 1. Product Description

### 1.1 Motor Pot Background

Motorized Potentiometers are used in a variety of industrial automation and process control applications. They are simple to use. Easy to set-up. No computers required. No software programs to write. Easy to maintain. Never obsolete.

The on-board potentiometer(s) provide absolute positional feedback information or function as the variable resistor in an analog control or bridge circuit. A motorized potentiometer provides a smooth uniform ramp throughout its timing cycle. Rotary limit switches are programmed (via the cams) to electrically control events (or provide status) at pre-set stages. Applications include ramping up the field current of a DC motor or controlling the start-up of a generator.

It can be very expensive to automate older control systems with manual-controlled potentiometers, rheostats or rotary cam switches. Using commonly available 4–20mA loop control, the MR267 offers a simple and inexpensive solution.

### 1.2 MR267 Current Loop Control (CLC) Option

The MR267 Current Loop Controller (CLC) option is designed to remotely control a Motorized Potentiometer (a.k.a. motor pot) via 4-20mA current loop or via a remotely located 10k ohm potentiometer. The motor controller will position the motor pot to any desired position within the mechanical range of the potentiometer (0-330 degrees for a single-turn pot, 10-turns for a ten-turn pot).

The CLC control option offers 4 programmable modes of operation (via jumpers):

1. (Standard) 4-20mA current loop control
2. Optional 0-20mA current loop control
3. Optional 0-2.5V voltage control
4. Optional control via External Potentiometer

Besides the motor pot configuration specified by the user (type, wattage rating and number of potentiometers, type and number of cam/limit switch channels as well as cycle period), the elements of the MR267 CLC control option are shown in **Figure 1**.

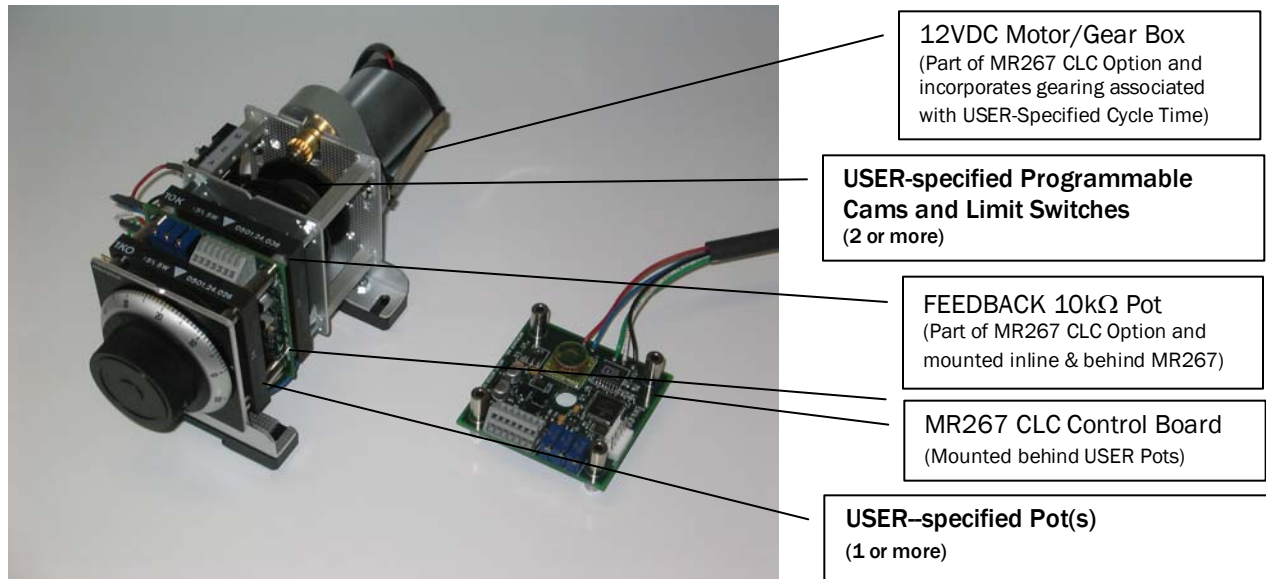

**Figure 1. Micronor Motor Pot With Installed MR267 CLC Option.**

To operate the Motor Pot with CLC option, the operational requirements are:

- Connection to 20-26 VDC power supply
- Connection to 4-20mA input control signals
- Program Cams and Connect Limit Switches
- Set SPEED trimpot to desired speed
- Set POSITION A trimpot to Zero Position (corresponding to 4mA input)
- Set POSITION B trimpot to Full Scale Position (corresponding to 20mA input)

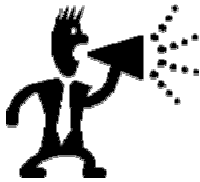

#### **A Note About Factory Settings**

- Unless otherwise specified at time of order, the PCB is setup for standard 4-20mA input control (Mode 1)
- The 3 trimpots are supplied pre-set by the factory according to the type and range of the 10kΩ FEEDBACK potentiometer. This pot is usually the same type (1- or 10-turn) and mechanical range as the user specified pots (but lower wattage).

## 2. Warranty Information

MICRONOR warrants this product to be free from defects in material and workmanship for a period of 1 (one) year from date of shipment. During the warranty period we will, at our option, either repair or replace any product that proves to be defective. To exercise this warranty, write or call your local MICRONOR representative, or directly contact the MICRONOR offices in the U.S. or Switzerland. You will be given prompt assistance and return instructions. Send the instrument, transportation prepaid, to the indicated service facility. Repairs will be made and the instrument returned transportation prepaid. Repaired products are warranted for the balance of the original warranty period, or at least 90 days.

### 2.1 Limitations of Warranty

This warranty does not apply to defects resulting from unauthorized modification or misuse of any product or part. This warranty also does not apply to Fiber Optic Connector interfaces, fuses or AC line cords.

**This warranty is in lieu of all other warranties, expressed or implied, including any implied warranty of merchantability of fitness for a particular use. MICRONOR shall not be liable for any indirect, special or consequent damages.**

### 2.2 Contact Information

In Europe:  
Micronor AG  
Pumpwerkstrasse 32  
CH-8015 Regensdorf  
Switzerland

Phone: +41-44-843-4020  
Fax : +41-44-843-4039  
Email: [sales@micronor.ch](mailto:sales@micronor.ch)  
URL: [www.micronor.ch](http://www.micronor.ch)

### 3. Specifications

Parameter	Specification	Notes
Position Input current	4mA to 20mA  -25mA min. +25mA max.	Normal signal input (position)  Signals $\leq$ 4mA are interpreted as 0 position. Signals $\geq$ 20mA are interpreted as 20mA signal.
Position input voltage	0V to 2.5V  -1V min. +5V max.	Normal signal input (position)  Voltages with the appropriate current limits
Input Burden	130 $\Omega$ max.	2.6V at 20mA input
Reference Load	5k $\Omega$ min.	Max. current draw from 2.5V reference is 1mA
Position Accuracy:	0.5% of full scale	
Position Resolution	0.25% typical	
Speed (SPEED)	5s to 25s	Adjustment range via SPEED trimpot. Actual range depends on the user-specified time period (Txs) and associated motor gearing.
Offset range (POS A)	0% to 52%	Relative to full scale via POS A trimpot
Span (POS B)	15% to 300%	Adjustment via POS B trimpot.  When adjusted to 15% pot will reach only 15% of full scale for 20mA input. When adjusted to 300%, pot will reach full scale at approx. 8mA input.
Supply Voltage	20V to 26V DC	
Supply Current Standby Running Peak	< 35mA 200mA typical. 500mA max.	When the motor has reached position, the current consumption is reduced to standby current. During a typical move, the current draw is approximately 200mA. Start and stop peaks may reach the peak maximum. Recommended power supply is 24V at 400mA current (continuous).
Temperature Operating Storage	-10 °C to +65 °C -25 °C to +75 °C	

Specifications subject to change without notice

## **4. Initial Preparation**

### **4.1 Unpacking and Inspection**

The unit was carefully inspected mechanically and electrically before shipment. When received, the shipping carton should contain the following items listed below. Account for and inspect each item before the carton is discarded. In the event of a damaged instrument, write or call your nearest MICRONOR office in either the U.S. or Switzerland. Please retain the shipping container in case reshipment is required for any reason.

### **4.2 Damage in Shipment**

All instruments are insured when shipped by MICRONOR. If you receive a damaged instrument you should:

- 1) Report the damage to your shipper immediately.
- 2) Inform MICRONOR
- 3) Save all shipping cartons.

Failure to follow this procedure may affect your claim for compensation.

### **4.3 Standard Contents**

Contents will consist of:

- Motor Pot unit (part number depends on configuration) with MR267 CLC option installed
- TDxxxx data sheet supplied if custom (non-standard) configurations
- WAGO Type 233-335 Wiring Tool
- MICRONOR Type PSN (Black) Cam Programming Key (one supplied with each shipment)
- MR267 User Guide (this document, one copy supplied with each shipment)

## 5. Installation Guidelines

### 5.1 Mounting the Motor Pot

There are a variety of Motor Pot configurations; each with its own mounting configuration. Consult the product's data sheet for details.

Most Motor Pots are ordered with the DIN rail mounting configuration (see **Figure 2**). These units can also be mounted directly to a panel by removing the two DIN Rail Adapters (via 2 screws each) mounted to the bottom flanges of the Motor Pot.

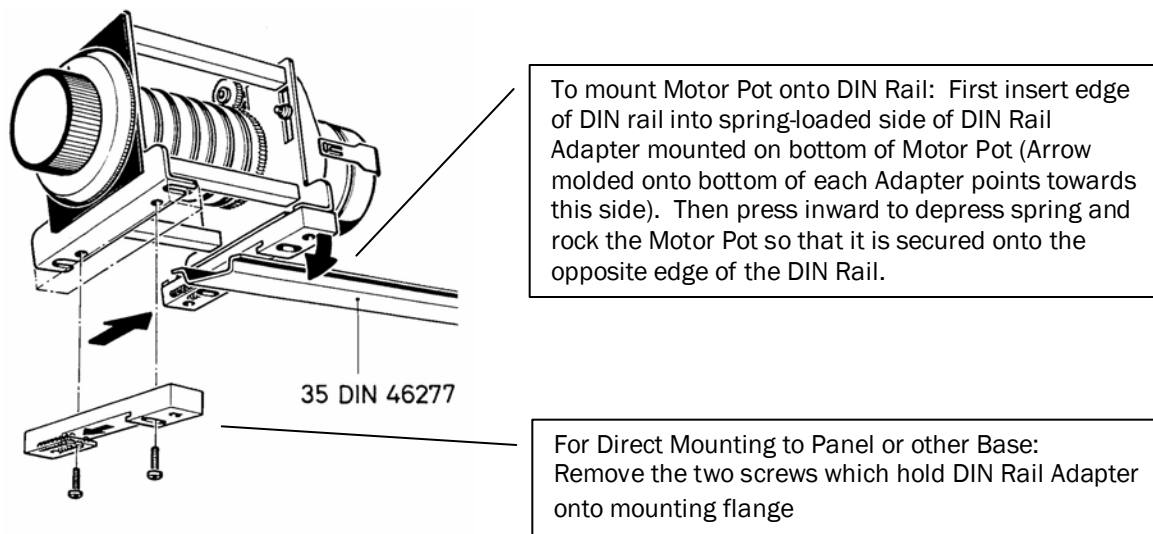

Figure 2. Direct and DIN Rail Mounting Options for Motor Pots.

### 5.2 Wiring Options and Connections To The MR267 Control Board

**Figure 3** provides a detailed view of the MR267 control board. To start, we will assume that the user wishes to operate in standard Mode 1 with 4-20mA external control of the Motor Pot. For basic operation in this mode, the user needs to do the following:

- Connect power between J1-4 (20-26VDC) and J1-5 (Ground)
- Connect current loop input between J1-1 (Input) and J1-3 (Ground, if needed)
- Verify SPEED, POS A and POS B trimpot settings per Section 5.4
- Connect to the USER Pot(s) per Section 5.5
- Program USER cams and connect limit switches per Section 5.6

Figure 3. Wiring Reference For MR267 CLC Board.

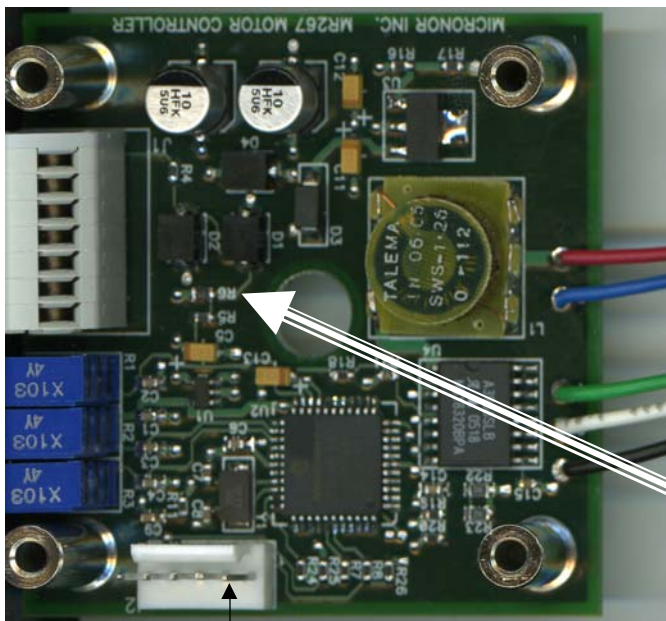
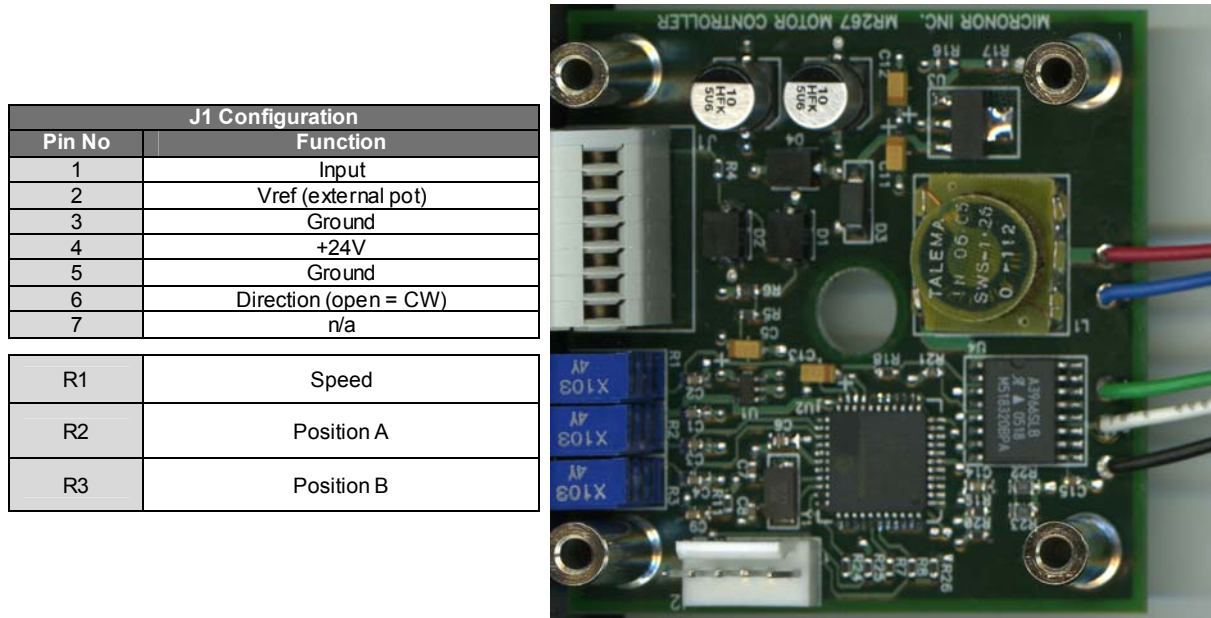

Wire Interface	
Pin No	Function
4	Motor+ (red)
3	Ground CCW (blue)
1	Vref CW (green)
2	Feedback (white)
5	Motor- (black)

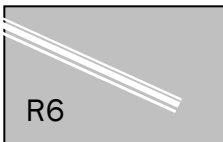

J2 Auxiliary	
Pin No	Function
1	Ground
2	+5V
3	Enable
4	n/a
5	Offset

### 5.3 Selecting and Wiring MR267 Mode of Operation

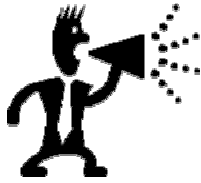

#### **A Note About Factory Settings**

- Unless otherwise specified, the Motor Pot with MR267 option is pre-set for 4-20mA control (Mode 1, see below). That is, the 12 VDC motor and 10k $\Omega$  feedback potentiometer are hardwired (5 wires) to the MR267 control board. Do not disturb this wiring!
- If the user wishes to change the Mode himself, please contact Micronor for instructions on disassembling the Motor Pot enough to gain access to the MR267 PCB.

The MR267 CLC option offers 4 selectable modes of operation:

Mode	Description	What Needs To Be Done
1	4-20mA current loop control	<b>Standard Mode</b> <b>Modifications Required:</b> none <b>Input:</b> Apply between J1-1 (Input) and J1-3 (Ground)
2	0-20mA current loop control	<b>Modifications Required:</b> Disable the 4mA loop bias by installing jumper between J2-1 to J2-5. <b>Input:</b> Apply between J1-1 (Input) and J1-3 (Ground)
3	Control via external 0-2.5V input	<b>Modifications Required:</b> Remove R6 and install jumper between J2-1 to J2-5 <b>Input:</b> Apply external voltage input between J1-1 (Input) and J1-3 (Ground)
4	Control via external 5-20k $\Omega$ Potentiometer using the on-board 2.5V reference voltage	<b>Modifications Required:</b> Remove R6 and install jumper between J2-1 to J2-5 <b>Input:</b> Connect external potentiometer with one end connected to J1-2 (2.5V reference), wiper to J1-1 and opposite end to J1-3 (Ground)

For ease of making connections, the MR267 features a WAGO PCB-mounted wiring strip (WAGO 733-366, [www.wago.com](http://www.wago.com)) with CAGE CLAMP® wire retention. These wiring strips offer direct, non-screw connections and accept wires (solid, stranded and tinned) from AWG 28-20 or 0.08-0.5 mm<sup>2</sup>.

As shown in **Figure 4**, following these steps to make connections to J1 power and signal inputs:

1. Strip the wire approx. 0.22" (5mm to 6mm) length.
2. Insert the white operating tool into the square hole of the terminal strip.
3. Then insert the stripped wire all the way down in the lower rectangular hole and remove the operating tool.
4. To remove any wires, simply insert the white WAGO tool into the square hole, pull to release the wire and then remove the tool.

Assuming that the initial Motor Pot adjustments and settings are correct, the user may proceed directly to Section 5.5 and make connections to his system.

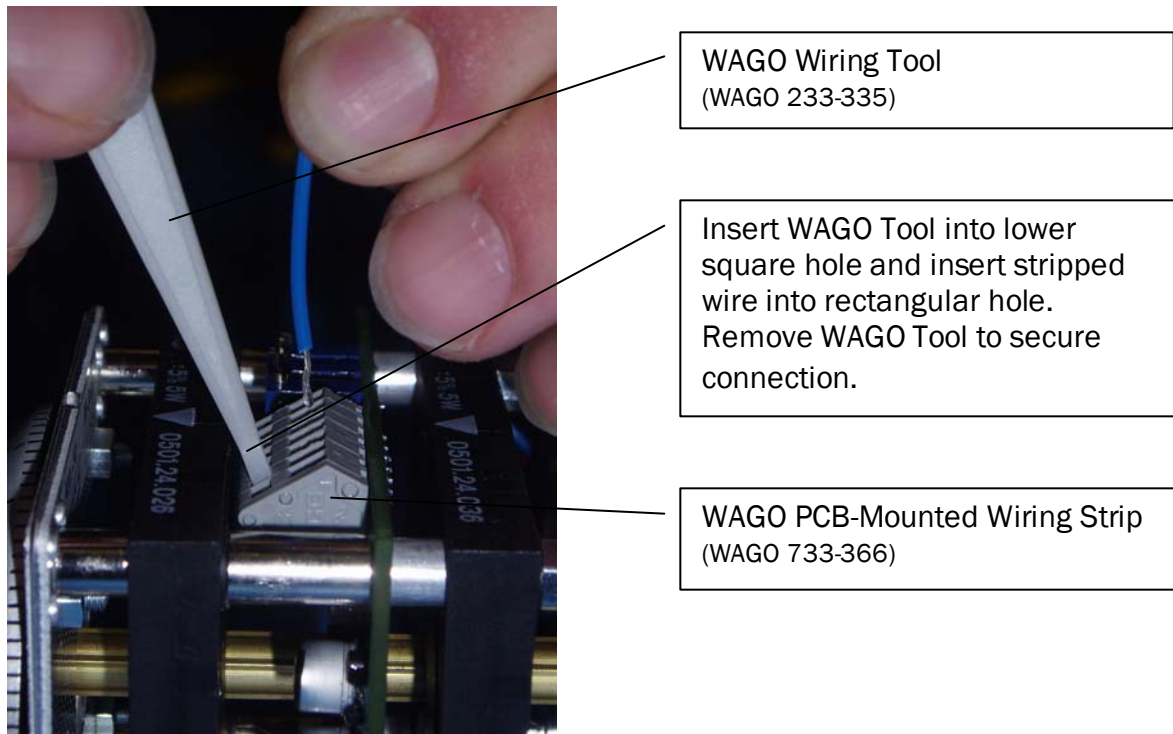
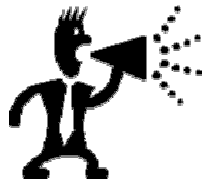

Figure 4. Making Connections To The WAGO Wiring Strip (J1).

## 5.4 Setting SPEED and POSITION Trimpot Settings on MR267 CLC Board



### **A Note About Factory Settings**

- The Motor Pot comes pre-set at the factory according to the customer-specified Time Period. This section can be used to change the setting (the MR267 offers the ability to slightly increase or decrease end-to-end speed).
- Without changing the trimpot settings, this section can be used to verify proper operation of the Motor Pot/MR267 combination

This section assumes that the initial settings need to be changed. If not, start by verifying the factory settings per Section 5.7.

These instructions assume a 1-turn potentiometer configuration and standard 4-20mA control operation (in Mode 1):

- Step 1 With power off, turn dial knob fully CCW until the mechanism reaches the Stop Pin limit (as shown in **Figure 5**. If dial reads '0', then skip to Step 3.
- Step 2 Adjust outer dial (without turning knob) to read '0' (aligned with arrow and notch at top of motor pot assembly). Turn POS A trimpot fully CCW. Everything should then appear as shown in **Figure 5**.

- Step 3 Turn power on and adjust current from 0 to 4mA ( $\pm 0.1$ mA). Over this range, the motor pot should not change position and a potentiometer connected to the User Pot should read nearly zero  $\Omega$ .
- Step 4 Set current input to 20mA. The dial should advance to the '100' full scale position (0-100 dial). If the dial does not read '100', then slowly adjust POS B trimpot to '90' and then slowly advance to the 100' position (where the potentiometer should also read its full scale value). **NOTE: If you don't do this step slowly, then you will overset the POS B trimpot setting - which will be very evident in the next step.**
- Step 5 Set current input to 12mA. If the motor pot stops at the '50' mid-scale dial setting, then advance to Step 6. Otherwise, POS B was overset in Step 4. Slowly turn POS B in the CCW position until the motor pot comes to the '50' position. Then go back to Step 4 to re-verify the '100' full scale position.
- Step 6 With the 4-20mA range now properly set, we now want to verify (or change) the Time Period (or Cycle Time). Set input to 4mA to set the Motor Pot to the '0' dial position (zero ohms on the User Pot). Then quickly set to 20mA and with a stop watch, measure the time for the potentiometer to travel to the '100' full scale dial position (corresponds to full-range value of the User Pot). If too fast or too slow, adjust the SPEED trimpot (CCW is slow and CW is faster) and repeat this step until the 0-100 cycle period is correctly set.

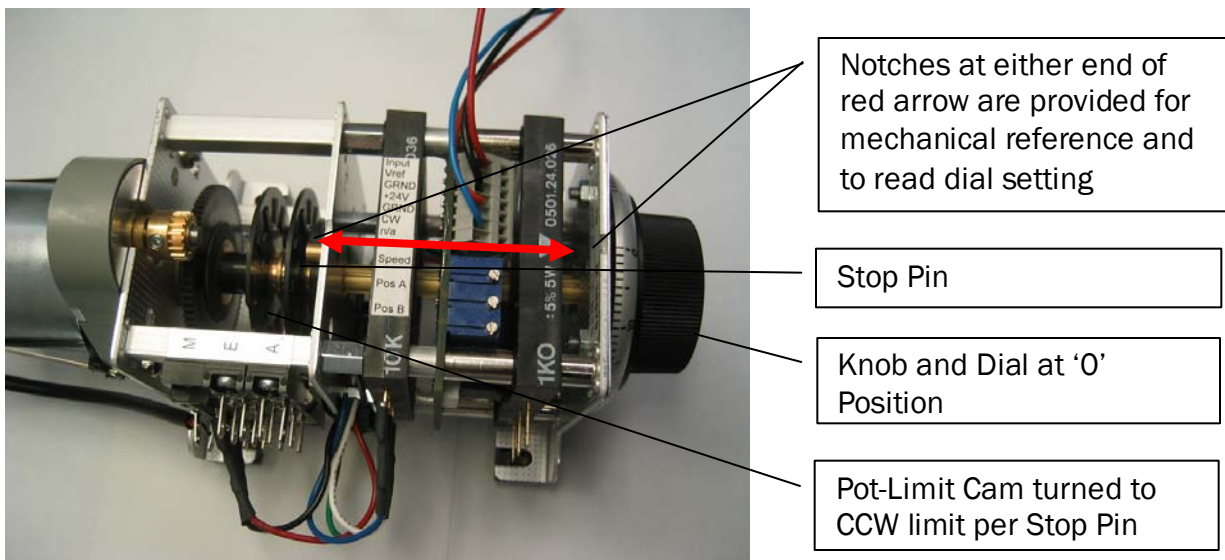

Figure 5. Photograph of Motor Pot Set to '0' Position.

## 5.5 Wiring to USER Potentiometer(s)

Motor Pots can be supplied with a variety of different potentiometers based on number of turns (1-turn or 10-turn), full-range ohm value, type (wire-wound or composite) and wattage. The most common Micronor Motor Pot configurations incorporate the standard DPC series (square-shaped design which is mounted inline with the shaft, cams, switches and diall – used in Motor Pot example of **Figure 1**). While you can solder to this potentiometer's terminals, it is recommended to use crimp-on receptacles which make it easier to pre-wire harnesses as well as facilitate removal/installation of replacement potentiometers.

For crimp wiring to DPC series potentiometers (detailed photo and drawing shown in **Figure 6**), use Tyco Electronics/AMP FASTON crimp-on receptacles for tab size 0.110-in Wide x 0.016-in Thick (2.8 x 0.5mm, DIN 46244 A). One example of a compatible receptacle is AMP 60118-1 (Digi-Key A27748CT-ND).

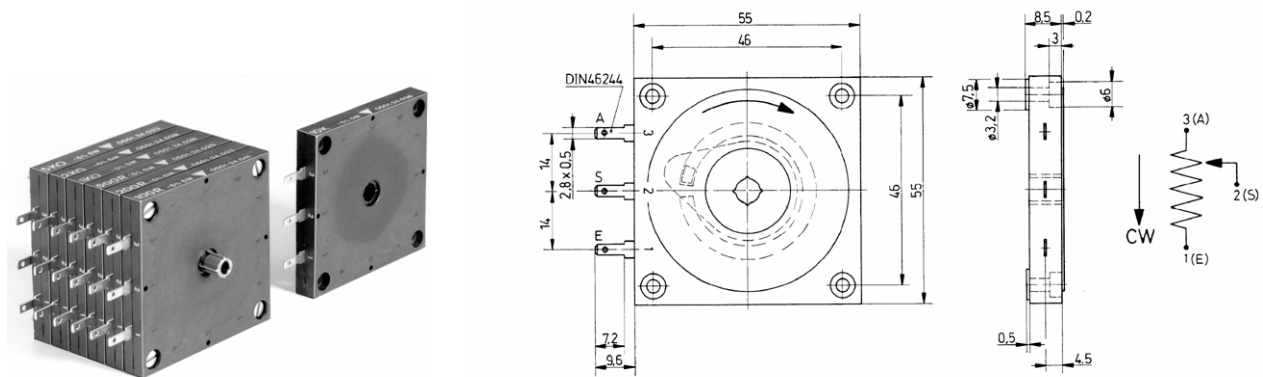
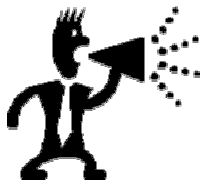

Figure 6. Wiring Diagram For DPC Series USER Potentiometers.

## 5.6 Cam Programming and Limit Switch Wiring



### **A Note About Factory Cam Programming**

- Unless otherwise specified, Cam/Switch 1 will be adjusted for the 0 ohms positions and Cam/Switch 2 will be adjusted for the Full Range setting (end) of the potentiometer.

Your Motor Pot has two or more Cam/Limit Switch channels (refer back to **Figure 1**). Each switch has three connections: COMMON, NC and NO. While you can solder to the switch's terminals, it is recommended to use crimp-terminals which make it easier to pre-wire harnesses as well as facilitate removal/installation of replacement switches.

- For standard KS25B3 (open style) Microswitches, use Tyco Electronics/AMP FASTON crimp-on receptacles for tab size 0.110-in Wide x 0.016-in Thick (2.8 x 0.5mm, DIN 46244 A). One example of a compatible receptacle is AMP 60118-1 (Digi-Key A27748CT-ND).
- For the S84 (enclosed style) Microswitches, use Tyco Electronics/AMP FASTON crimp-on receptacles for tab size 0.258-in Wide x 0.031-in Thick (6.3 x 0.8mm). One example of a compatible receptacle is AMP 60384-1 (Digi-Key A27679CT-ND)

The Micronor Programmable Cam Switches are designed to be both versatile and easy to operate. These are detailed instructions regarding the actual programming of the switches. Should you have any questions or concerns, our support engineers would be glad to assist you.

Initial planning is required for cams to be programmed to function as desired. Due to the design of the cam, switches can not be disengaged for more than 180°. If the system requires that the switch does not make contact for more than 180°, the normally closed contact must be wired.

As in Example A, a system might require that the connection for a switch be made from 0° to 30° and there be no connection from 31° to 359°. To accomplish this, the switch must be wired in the normally closed position.

As in Example B, a system that requires a connection for 315°, the normally open contact must be wired so that a connection is made when the switch is engaged, and no connection is made when the switch is disengaged.

The following instructions may be used to program the start and stop times of the switch.

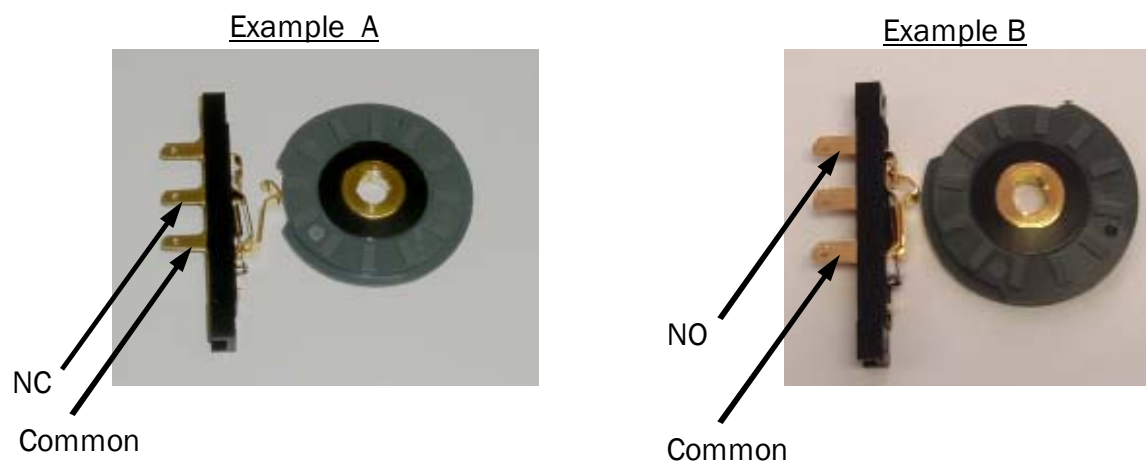

**Figure 7. Examples of Cam Programming and Switch Response.**

**Programming Using the PSN Key for NK4201 (Double Cam) and NK 4101 (Single Cam)**

- Step 1 Insert the key into unit, as shown in the figure, with the numbered side away from the cam and the notched side towards the cam.

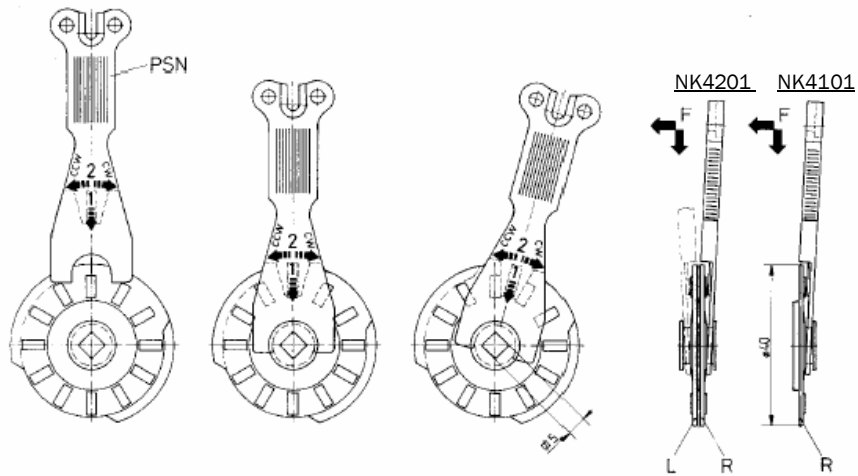

- Step 2 While gently applying pressure against the cam with the key; rotate the cam to the desired position.



- Step 3 For double cams (NK 4201), adjust the other side of the cam by flipping over the key and repeating steps 1 and 2 on the other side of the cam.
- Step 4 Test the unit to confirm that the switches engage and disengage at the appropriate positions.

## 5.7 First Time Start-Up and Performance Verification

- Step 1 With power connector on, set current input to 4 mA. The dial should reset itself to the 0 position (on 0-100 labeled dials). If not, go back to Section 5.4.
- Step 2 Set current input to 12 mA. The dial should advance to either the '50' mid-scale position (for 0-100 dial scale). If not, go back to Section 5.4.
- Step 3 Set current input to 20mA. The dial should advance to the 100 full scale position (for 0-100 dial scale). If not, go back to Section 5.4.
- Step 4 To verify Cycle Time, first set the input to 4mA (corresponding to 0 position). Then quickly switch to 20mA and with a stop watch, measure the time period for the potentiometer to travel 0-100. If too fast or too slow, go back to Section 5.4.
- Step 5 The Motor Pot and MR267 CLC Control option are properly adjusted and ready for use.

## 6. Maintenance and Service

### 6.1 Replacing Microswitches

Age and heavy duty cycles can eventually wear out the microswitches. Either type (KS25B4 or S84) can be purchased as replacement parts

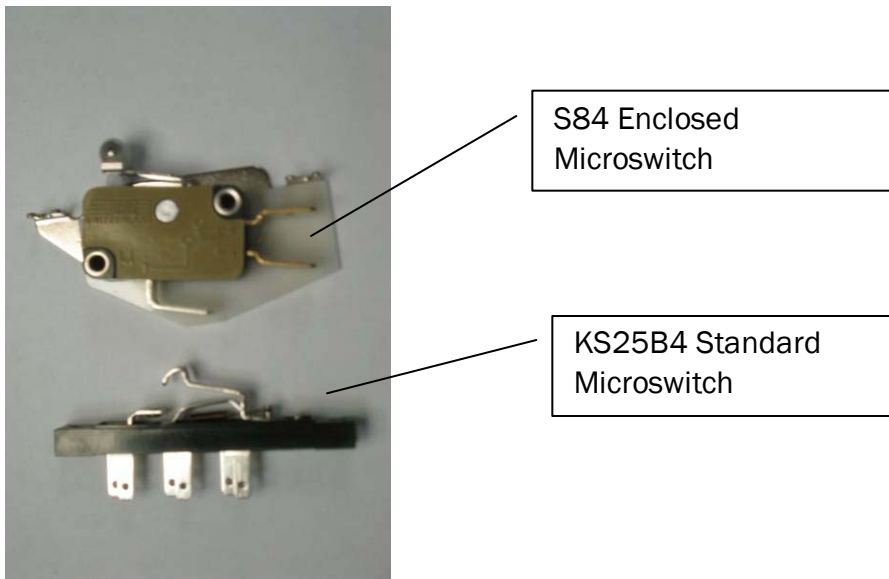

**Figure 8. Photograph Showing KS25B4 and S84 Microswitches.**

To replace a microswitch, follow these steps:

- Step 1 Remove the existing connections to the old switch. (This is a good reason for using FASTON crimp-on receptacles for ease of connecting and disconnecting pots and limit switches.)
- Step 2 Remove the two screws holding the microswitch in place to the motor pot frame.
- Step 3 Replace with the new switch by remounting with same screws and then reconnecting the wiring.

## 7. Reference Documents

The following reference drawings and data sheets follow in this section:

- MICRONOR 9200.00.047 Motor Pot With 4-20mA Input Control (Reference Drawing)
- MICRONOR MPP Series 1-Turn (Side Mount) Motor Pot
- MICRONOR MPR Series 1-Turn (End Mount) Motor Pot
- MICRONOR MP Series Custom 1-Turn (Side Mount) Motor Pot
- MICRONOR MPZ Series 10-Turn (Side Mount) Motor Pot
- MICRONOR MPRZ Series 10-Turn (End Mount) Motor Pot
- MICRONOR DPC Series 1-Turn 5W Wirewound Potentiometer
- MICRONOR DPM Series High Power (20-60-170W) 1-Turn Composite Potentiometers
- MICRONOR DPZ Series Precision 10-Turn 2W Wirewound Potentiometer



# 1 Gang-Motorpotentiometer 1 Turn-Motorized potentiometer

## Serie MPP

- **Feindrahtpotentiometer** Wire-wound potentiometer **R1...R5 (5W)**
- **Widerstandswerte** Resistance **100R...100K (Ω)**
- **Endlagenkontakte einstellbar** Adjustable limit switches **2**
- **Nutzkontakte (frei programierbar)** Program channels (free setting) **1...7**
- **Schnellbefestigung** Quick rail mounting **35 DIN 46277 / EN 50022**

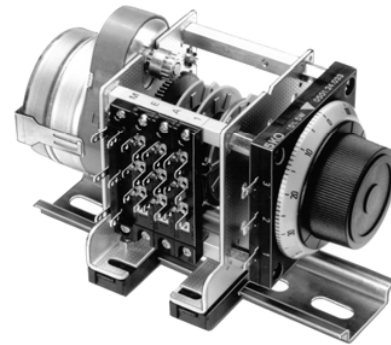

Bestelltext <b>Typ</b> Potentiometer	How to order <b>Type</b> Potentiometer	Motorpotentiometer <b>MPP4109 C9 T120s 220V50Hz R2</b> R1 = 100R / R2 = 100K (DPC)
--	--	--

Bestellschlüssel	Order key	<b>MPP41xx xx Txs xV Rx</b>					
Serie Schrankeinbau (Schnellbefestigung)	Serie internal quick rail mounting	<b>03</b>	<b>06</b>	<b>09</b>			
Baugrösse	Size	47	71	95			
Mass (L) mm	Dimension (L) mm						
<b>Anzahl Schalter</b>	Number of switches	<b>3</b>	<b>6</b>	<b>9</b>			
Endlagenkontakte einstellbar	Adjustable limit switches (NK4101/20°)	2	2	2			
Nutzkontakte frei programierbar	Program channels free setting (NK4201)	1	4	7			
<b>Hochlaufzeit in (s)</b>	Cycle times (s)	<b>T =</b>	0...100%				
		<b>10 15 20 30</b>					
		<b>45 60 75 90 120</b>					
<b>Synchronmotor</b>	Synchronous motor	<b>C</b>	(CW / CCW)				
Anschluss Spannung (AC)	Power supply (AC)	<b>24</b>	24V				
Frequenz 50Hz (60Hz)	Frequency 50Hz (60Hz)	<b>48</b>	48... 50V				
		<b>110</b>	110...120V				
		<b>220</b>	220...240V				
<b>Gleichstrommotor</b>	DC-Motor	<b>G</b>	(CW / CCW)				
Anschluss Spannung (DC)	Power supply (DC)	<b>24</b>	24V ±10%				
		<b>12<sup>1)</sup></b>	12V ±10%				
<b>Feindrahtpotentiometer</b>	Wire-wound potentiometer	<b>R1...R5 (Typ DPC)</b>					
Widerstandswert / Auflösung	Resistance / Resolution						
<b>100R / 0,131%<sup>1)</sup></b>	<b>200R / 0,111%<sup>1)</sup></b>	<b>500R / 0,083%</b>	<b>1K0 / 0,079%</b>	<b>2K0 / 0,076%</b>	<b>5K0 / 0,059%</b>	<b>10K / 0,044%</b>	
<b>20K / 0,033%<sup>1)</sup></b>	<b>100K / 0,020%<sup>1)</sup></b>						

Massbild / Outline drawing

<sup>1)</sup> Auf Anfrage / On request

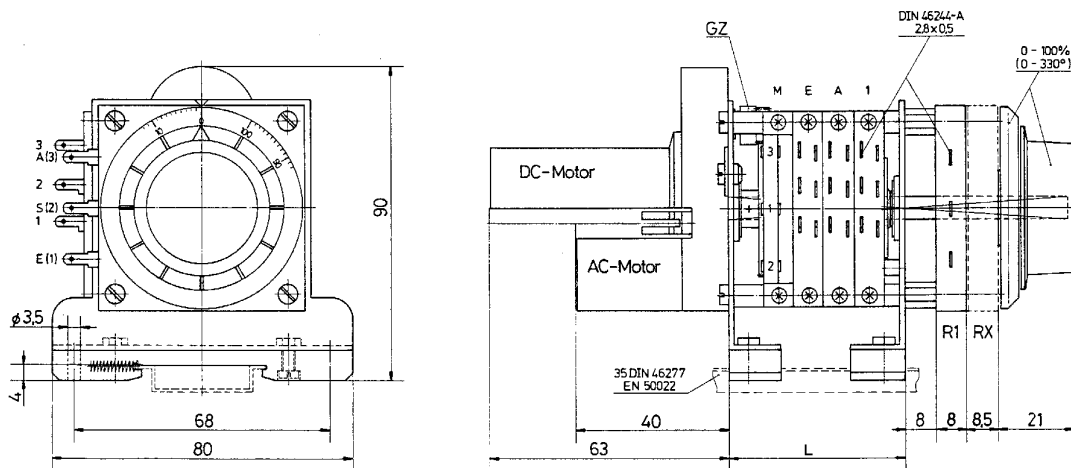

## 1 Gang-Motorpotentiometer

### 1 Turn-Motorized potentiometer

## Serie MPR

- **Feindrahtpotentiometer**  
Wire-wound potentiometer
- **Widerstandswerte**  
Resistance
- **Endlagenkontakte einstellbar**  
Adjustable limit switches
- **Nutzkontakte** (frei programierbar)  
Program channels (free setting)
- **Rückwand- Schnellbefestigung**  
Quick rail base mounting

R1...R2 (5W)  
100R...100K (Ω)  
2  
1...4  
35 DIN 46277 / EN 50022



Bestelltext  
**Typ**  
Potentiometer

How to order  
**Type**  
Potentiometer

Motorpotentiometer  
**MPR4103 C3 T90s 220V50Hz R2**  
R1 = 200R / R2 = 5K0 (DPC)

### Bestellschlüssel

### Order key

### MPR41xx xx Txs xV Rx

Serie Rückwand- Schnellbefestigung  
Baugröße  
Mass (L) mm

Serie Quick rail base mounting  
Size  
Dimension (L) mm

<b>02</b>	<b>03</b>	<b>06</b>
39	47	71

**Anzahl Schalter**  
Endlagenkontakte einstellbar  
Nutzkontakte frei programierbar

Number of switches  
Adjustable limit switches (NK4101/20°)  
Program channels free setting (NK4201)

<b>2</b>	<b>3</b>	<b>6</b>
2	2	2
-	1	4

**Hochlaufzeit** in (s)

Cycle times (s)

T = 0...100%  
**10 15 20 30**  
**45 60 75 90 120**

**Synchronmotor**  
Anschluss Spannung (AC)  
Frequenz 50Hz (60Hz)

Synchronous motor  
Power supply (AC)  
Frequency 50Hz (60Hz)

**C** (CW / CCW)  
**24** 24V  
**48** 48... 50V  
**110** 110...120V  
**220** 220...240V

**Gleichstrommotor**  
Anschluss Spannung (DC)

DC-Motor  
Power supply (DC)

**G** (CW / CCW)  
**24** 24V ±10%  
**12<sup>1)</sup>** 12V ±10%

**Feindrahtpotentiometer**  
Widerstandswert / Auflösung

Wire-wound potentiometer  
Resistance / Resolution

R1...R5 (Typ DPC)

<b>100R</b> / 0,131%	<b>200R</b> / 0,111%	<b>500R</b> / 0,083%	<b>1K0</b> / 0,079%	<b>2K0</b> / 0,076%	<b>5K0</b> / 0,059%	<b>10K</b> / 0,044%
<b>20K</b> / 0,033% <sup>1)</sup>	<b>100K</b> / 0,020% <sup>1)</sup>					

Massbild / Outline drawing

<sup>1)</sup> Auf Anfrage / On request

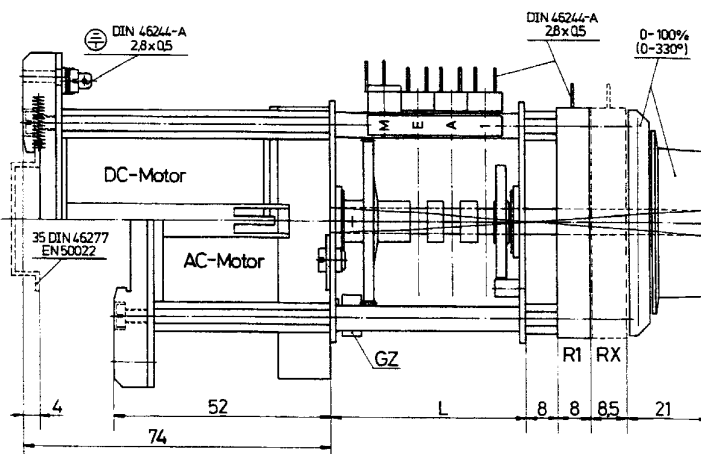
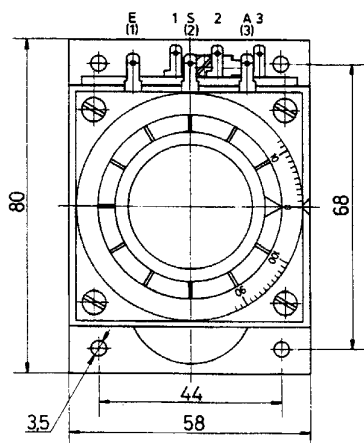

## 1 Gang-Potentiometerantrieb

### 1 Turn-Potentiometer drive

Serie **MP**

- **Zum Anbau von Potentiometer**  
To mount external potentiometer
- **Anzahl Potentiometer** **1...3**  
Number of Potentiometer
- **Widerstandswerte** **100R...10K (Ω)**  
Resistance
- **Endlagenkontakte einstellbar** **2**  
Adjustable limit switches
- **Nutzkontakte (frei programierbar)** **1...7**  
Program channels free setting
- **Schnellbefestigung** **35 DIN 46277 / EN 50022**  
Quick rail mounting



Bestelltext

Typ

How to order

Type

Motorpotentiometer

**MP4103 C3 T90s 220V50Hz**  
 1 x PZK96.600

Bestellschlüssel

Order key

**MP41xx xx Txs xV**Serie  
BaugrößeSerie  
Size**03 06 09****Anzahl Schalter**Endlagenkontakte einstellbar  
Nutzkontakte (frei programierbar)  
Mass (L) mmNumber of switches  
Adjustable limit switches  
Program channels (free setting)  
Dimension (L) mm

<b>3</b>	<b>6</b>	<b>9</b>
2	2	2 (NK4101.20°)
1	5	7 (NK4201)
41	71	95

**Hochlaufzeit in (s)**

Cycle times (s)

 T = 0...100%  
**10 15 20 30 45 60 75 90**
**Synchronmotor**Anschluss Spannung (AC)  
Frequenz 50Hz (60Hz)Synchronous motor  
Power supply (AC)  
Frequency 50Hz (60Hz)

<b>C</b>	(CW / CCW)
<b>24</b>	24V
<b>48</b>	48... 50V
<b>110</b>	110...120V
<b>220</b>	220...240V

**Gleichstrommotor**Anschluss Spannung (DC)  
Auf AnfrageDC-Motor  
Power supply (DC)  
On request

<b>G</b>	(CW / CCW)
<b>24</b>	24V ±10%
<b>12</b>	12V ±10%

Bausatz für Potentiometer  
DrehwinkelMounting kit for Potentiometer  
Rotation angle**Potentiometer R (Seite / Page 19)**  
270° (Min. ... Max.)

Zahnrad PZK	inkl. (1x)	øJ	Gearwheel PZKincl. (1x)	øJ (inch)	Potentiometer R	øE	(inch)
1 x <b>PZK96.600</b>	-	6 mm	1 x <b>PZK96.635</b>	-	<b>R1</b>	48 mm	1.890
2 x <b>PZK96.600</b>	<b>ZZF36</b>	6 mm	2 x <b>PZK96.635</b>	<b>ZZF36</b>	<b>R1 + R2</b>	46 mm	1.810
3 x <b>PZK72.600</b>	-	6 mm	3 x <b>PZK72.635</b>	-	<b>R1 + R2 + R3</b>	35 mm	1.370

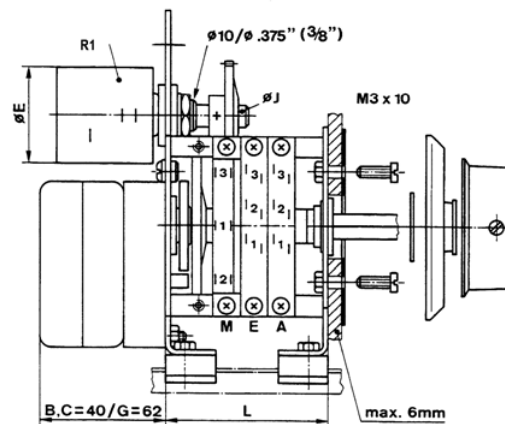
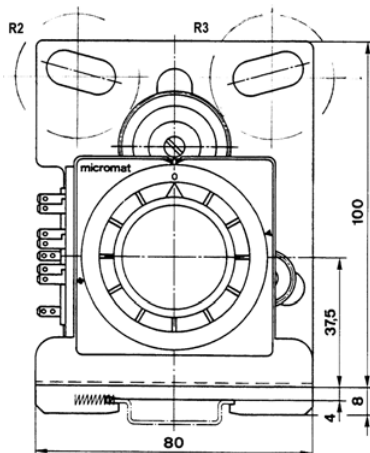
**Massbild / Outline drawing**

**10 Gang-Motorpotentiometerantrieb Serie MPZ**

10 Turn-Motorized potentiometer drive

- **Zum Anbau von Potentiometer**  
To mount external potentiometer
- **Anzahl Potentiometer** **1...3 (2W)**  
Number of potentiometer
- **Widerstandswerte** **100R...50K (Ω)**  
Resistance
- **Endlagenkontakte einstellbar** **2**  
Adjustable limit switches
- **Nutzkontakte** (frei programmierbar) **1...4**  
Program channels (free setting)
- **Schnellbefestigung** **35 DIN 46277 / EN 50022**  
Quick rail mounting



Bestelltext <b>Typ</b>	How to order <b>Type</b>	Motorpotentiometer <b>MPZ4109 C6 T90s 220V50Hz</b> 1 x PZK96.600
---------------------------	-----------------------------	--

Bestellschlüssel	Order key	MPZ41xx xx Txs xV
Serie	Serie	
Baugrösse	Size	<b>04 06 09</b>
<b>Anzahl Schalter</b>	Number of switches	<b>2 4 6</b>
Endlagenkontakte einstellbar	Adjustable limit switches	2 2 2 (NK4101.20°)
Nutzkontakte (frei programmierbar)	Program channels (free setting)	- 2 4 (NK4201)
Mass (L) mm	Dimension (L) mm	55 71 95
<b>Hochlaufzeit</b> in s (0...3600°)	Cycle times s (0...3600°)	T = 0...100% <b>20 30 45 60 90 120 180</b>
<b>Synchronmotor</b>	Synchronous motor	<b>C</b> (CW / CCW)
Anschluss Spannung (AC)	Power supply (AC)	<b>24</b> 24V
Frequenz 50Hz (60Hz)	Frequency 50Hz (60Hz)	<b>48</b> 48... 50V
		<b>110</b> 110...120V
		<b>220</b> 220...240V
<b>Gleichstrommotor</b>	DC-Motor	<b>G</b> (CW / CCW)
Anschluss Spannung (DC)	Power supply (DC)	<b>24</b> 24V ±10%
Auf Anfrage	On request	<b>12</b> 12V ±10%
Bausatz für Potentiometer	Mounting kit for Potentiometer	<b>Potentiometer R</b> (Seite / Page 19)
Drehwinkel	Rotation angle	270° (Min. ... Max.)

Zahnrad PZK	inkl. (1x)	∅J	Gearwheel PZK	inkl. (1x)	∅J (inch)	Potentiometer R	∅E	(inch)
1 x PZK96.600	-	6 mm	1 x PZK96.635	-	6,35	<b>R1</b>	48 mm	1.890
2 x PZK96.600	<b>ZZF36</b>	6 mm	2 x PZK96.635	<b>ZZF36</b>	6,35	<b>R1 + R2</b>	46 mm	1.810
3 x PZK72.600	-	6 mm	3 x PZK72.635	-	6,35	<b>R1 + R2 + R3</b>	35 mm	1.370

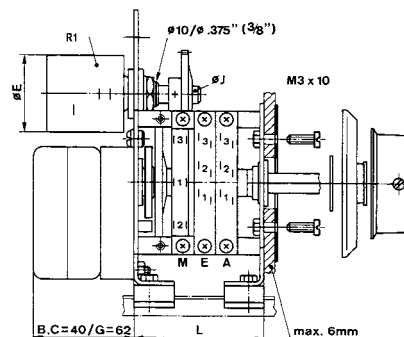
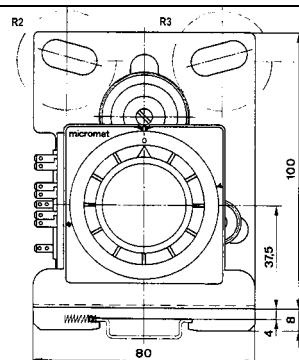
**Massbild / Outline drawing**

**10 Gang-Motorpotentiometer**  
10 Turn-Motorized potentiometer

Serie **MPRZ**

- **Feindrahtpotentiometer**  
Wire-wound potentiometer
- **Widerstandswerte**  
Resistance
- **Endlagenkontakte einstellbar**  
Adjustable limit switches
- **Nutzkontakte** (frei programierbar)  
Program channels (free setting)
- **Rückwand- Schnellbefestigung**  
Quick rail base mounting

**R1...R3** (2W)  
**100R...50K** ( $\Omega$ )  
**2**  
**1...4**  
**35 DIN 46277 / EN 50022**

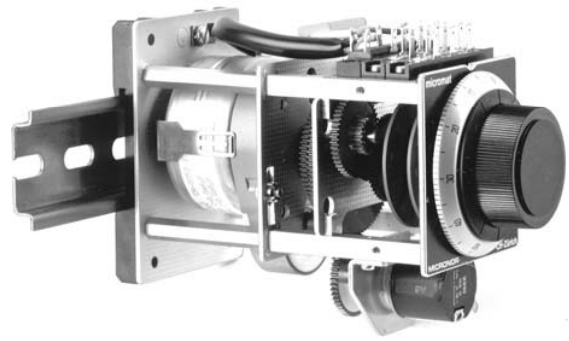

Bestelltext  
**Typ**  
Potentiometer

How to order  
**Type**  
Potentiometer

Motorpotentiometer  
**MPRZ4106 C4 T90s 220V50Hz R2**  
R1 = 100R / R2 = 50K (DPZ)

**Bestellschlüssel**

Order key

**MPRZ41xx xx Txs xV Rx**

Serie Rückwand- Schnellbefestigung  
Baugrösse  
Mass (L) mm

Serie Quick rail base mounting  
Size  
Dimension (L) mm

<b>04</b>	<b>05</b>	<b>06</b>
55	63	71

**Anzahl Schalter**  
Endlagenkontakte einstellbar  
Nutzkontakte frei programierbar

Number of switches  
Adjustable limit switches (NK4101/20°)  
Program channels free setting (NK4201)

<b>2</b>	<b>3</b>	<b>4</b>
2	2	2
-	1	2

**Hochlaufzeit** in s (3600°)

Cycle times s (3600°)

<b>T =</b>	0...100%		
<b>30</b>	<b>45</b>	<b>60</b>	
<b>90</b>	<b>120</b>	<b>180</b>	

**Synchronmotor**  
Anschluss Spannung (AC)  
Frequenz 50Hz (60Hz)

Synchronous motor  
Power supply (AC)  
Frequency 50Hz (60Hz)

<b>C</b>	(CW / CCW)
<b>24</b>	24V
<b>48</b>	48... 50V
<b>110</b>	110...120V
<b>220</b>	220...240V

**Gleichstrommotor**  
Anschluss Spannung (DC)

DC-Motor  
Power supply (DC)

<b>G</b>	(CW / CCW)
<b>24</b>	24V ±10%
<b>12<sup>1)</sup></b>	12V ±10%

**Feindrahtpotentiometer**  
Widerstandwert / Auflösung

Wire-wound potentiometer  
Resistance / Resolution

**R1...R3** (Typ **DPZ**)

**100R / 0,055%<sup>1)</sup>   200R / 0,032%   500R / 0,035%   1K0 / 0,029%   2K0 / 0,024%   5K0 / 0,018%   10K / 0,015%**  
**20K / 0,013%<sup>1)</sup>   50K / 0,010%<sup>1)</sup>**

**Massbild** / Outline drawing

<sup>1)</sup> auf Anfrage / On request

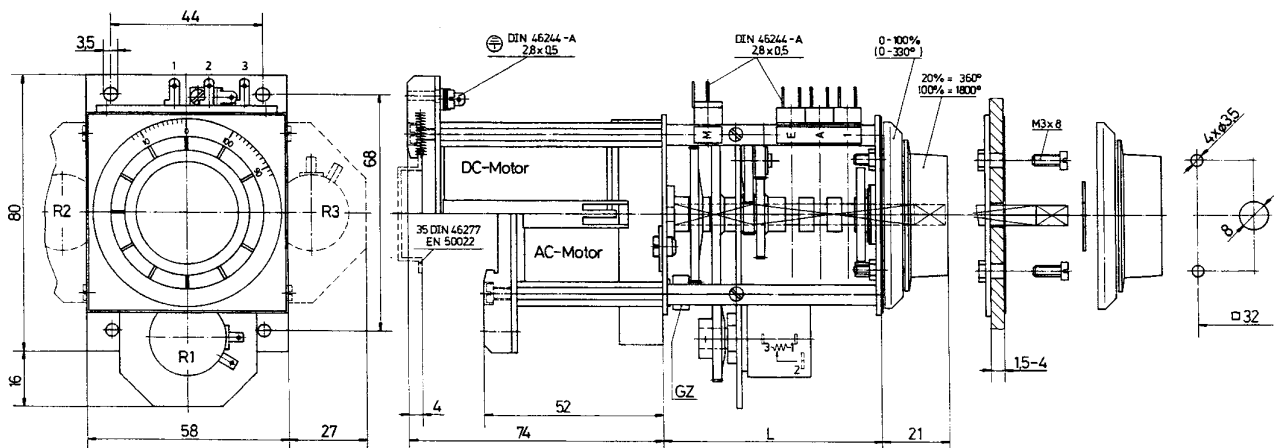

## 1 Gang-Feindrahtpotentiometer 1 Turn-Wire-wound potentiometer

Typ **DPC**

- **Widerstandswerte**  
Resistance **100R...100K (Ω)**
- **Hohe Auflösung**  
Excellent linearity **0,1...0,02%**
- **Belastbarkeit**  
Power rating **5W**
- **Stapelbar**  
Multi stocking **1...20**

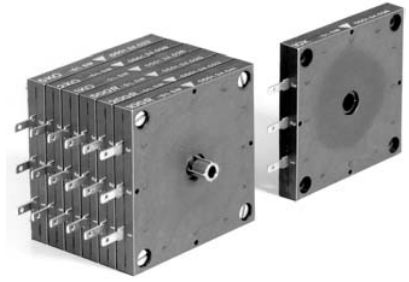
Bestelltext  
TypHow to order  
Type1 Gang-Feindrahtpotentiometer  
**DPC 100K**

Bestellschlüssel

Order key

**DPC x**

Serie

Serie

Widerstandswert / Auflösung

Resistance / Resolution

<b>100R</b> / 0,131% <sup>1)</sup>	<b>200R</b> / 0,111% <sup>1)</sup>	<b>500R</b> / 0,083%	<b>1K0</b> / 0,079%	<b>2K0</b> / 0,076%	<b>5K0</b> / 0,059%	<b>10K</b> / 0,044%
<b>20K</b> / 0,033% <sup>1)</sup>	<b>100K</b> / 0,020% <sup>1)</sup>					

<sup>1)</sup> auf Anfrage / On request

Drehwinkel mech. / elektr.  
Widerstandstoleranz  
Linearität  
Lebensdauer  
Belastbarkeit  
Schleiferstrom  
Temperaturkoeffizient (ENR)

Rotation angle mech. / electr.  
Resistance tolerance  
Linearity  
Rotation life  
Power rating  
Slider current  
Temperature coefficient (ENR)

0...330° = 0...100%  
±5 %  
<0,15 %  
1 Mill. Umdr. / Turns  
5 W (40 °C)  
100 mA  
40 ppm / °C nom. (-25 °C +105 °C)

Drehrauschen  
Endwiderstände  
Spannungsfestigkeit

Rotational noise  
End resistances  
Dielectric strength

100 Ω / 1 mA  
0,5 % R tot. 0,5 Ω  
900 V DC

Einstell Drehmoment  
Gleichlauf

Torque  
Synchronous run

0,5 Ncm  
0,5 %

Massbild

Outline drawing

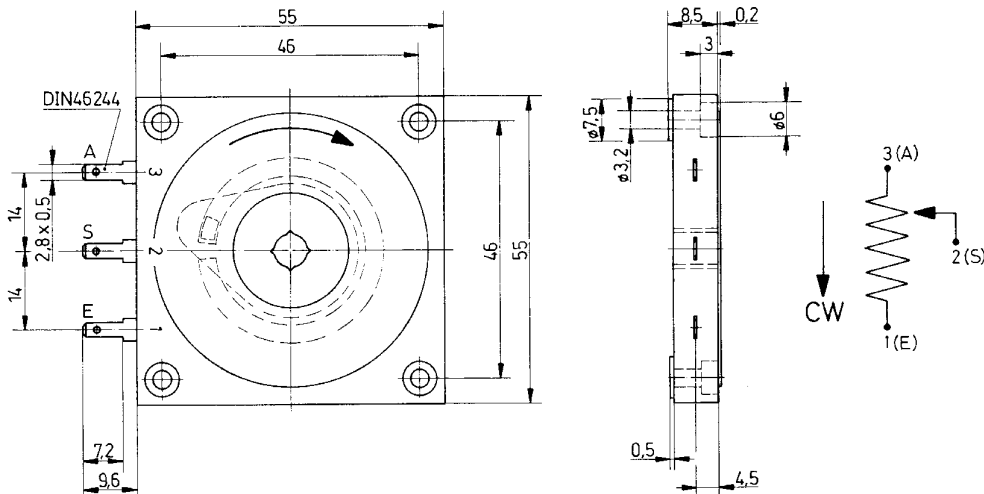

# 1 Gang-Drahtpotentiometer

## 1 Turn-Wire wound potentiometer

Serie **DPM 20 / 60 / 170**

- **Hohe Belastbarkeit** **20 / 60 / 170W**  
High Power rating
- **Widerstandswerte** **2R...50K (Ω)**  
Resistance
- **Schleifkontakt massiv Edelmetall**  
Slider contact, Solid contact material
- **Spannungsfestigkeit** **2000V AC 50Hz**  
Dielectric strength
- **Mech. Anschlag** **Ja / Yes**  
Mechanical stop

Bestelltext **Typ** How to order **Type** Drahtpotentiometer **DPM170.R50K**

**Bestellschlüssel**

Order key

**DPM x Rx**Serie  
**Belastung**Serie  
Power rating

**20** ( 20W)  
**60** ( 60W)  
**170** (170W)

**Widerstandswerte / Stromstärke (A)**

Resistance / Current intensity (A)

Serie **DPM 20**

<b>5R</b> / 2,00	<b>10R</b> / 1,41	<b>20R</b> / 1,0	<b>25R</b> / 0,89	<b>50R</b> / 0,63	<b>100R</b> / 0,44	<b>200R</b> / 0,316	<b>250R</b> / 0,282	<b>500R</b> / 0,200
<b>1K0</b> / 0,141	<b>2K0</b> / 0,100	<b>2K5</b> / 0,089	<b>5K0</b> / 0,063	<b>10K</b> / 0,044	<b>15K</b> / 0,036			

**Widerstandswerte / Stromstärke (A)**

Resistance / Current intensity (A)

Serie **DPM 60**

<b>2R</b> / 5,5	<b>3R</b> / 4,5	<b>5R</b> / 3,5	<b>10R</b> / 2,4	<b>20R</b> / 1,7	<b>25R</b> / 1,5	<b>50R</b> / 1,10	<b>100R</b> / 0,77	<b>200R</b> / 0,55
<b>250R</b> / 0,49	<b>500R</b> / 0,35	<b>1K0</b> / 0,24	<b>2K0</b> / 0,17	<b>2K5</b> / 0,15	<b>5K0</b> / 0,110	<b>10K</b> / 0,077	<b>15K</b> / 0,063	<b>20K</b> / 0,055

**Widerstandswerte / Stromstärke (A)**

Resistance / Current intensity (A)

Serie **DPM 170**

<b>2R</b> / 9,2	<b>3R</b> / 7,5	<b>5R</b> / 5,8	<b>10R</b> / 4,1	<b>20R</b> / 2,9	<b>25R</b> / 2,6	<b>50R</b> / 1,85	<b>100R</b> / 1,30	<b>200R</b> / 0,92
<b>250R</b> / 0,82	<b>500R</b> / 0,58	<b>1K0</b> / 0,41	<b>2K0</b> / 0,29	<b>2K5</b> / 0,26	<b>5K0</b> / 0,185	<b>10K</b> / 0,130	<b>15K</b> / 0,106	<b>20K</b> / 0,092
<b>25K</b> / 0,082	<b>50K</b> / 0,058							

**Technische Daten**

Widerstandstoleranz  
Belastung  
Drehwinkel elektr. / mech.  
Gewicht  
Masse

**Technical data**

Resistance tolerance  
Power rating  
Angle elctr. / mech.  
Weight  
Dimension

Serie DPM

	<b>20</b>	<b>60</b>	<b>170</b>
	±5%	±5%	±5%
	20W (20 °C)	60W (40 °C)	170W (40 °C)
	250° / 270°	260° / 270°	300° / 290°
<b>g</b>	70	170	460
<b>øD / ød</b>	35 / 6	50 / 6	80 / 6
<b>A</b>	M10x0,75	M12x1	M12x1
<b>SW</b>	14	16	16
<b>L / B</b>	24 / 10	20 / 12	28 / 12
<b>W / M</b>	90° / 26	90° / 33	60° / 53
<b>E</b>	M3	M3	M4
<b>T</b>	28	38	62

**Massbild****Outline drawing**

Masse / Dimension (mm)

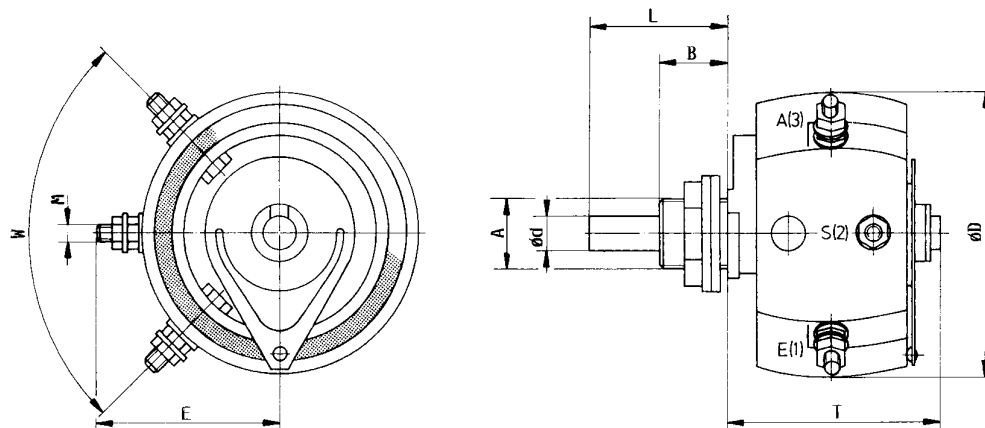

## 10 Gang-Prazision Feindrahtpotentiometer Typ DPZ (2W)

### 10 Turn Precision wire wound potentiometer

- **Widerstandswerte**  
Resistance **100R...50K ( $\Omega$ )**
- **Hohe Auflosung**  
Excellent linearity **0,01...0,05%**
- **Belastbarkeit**  
Power rating **2W**



Bestelltext  
**Typ** How to order  
**Type** 10-Gang Feindrahtpotentiometer  
**DPZ 50K**

**Bestellschlüssel** Order key **DPZ x**

Serie

Serie

**Widerstandwert / Auflosung**

Resistance / Resolution

**100R / 0,055%**<sup>1)</sup> **200R / 0,032%** **500R / 0,035%** **1K0 / 0,029%** **2K0 / 0,024%** **5K0 / 0,018%** **10K / 0,015%**  
**20K / 0,013%**<sup>1)</sup> **50K / 0,010%**<sup>1)</sup>

<sup>1)</sup> auf Anfrage / On request

Drehwinkel mech. / elektr.	Rotation angle mech. / electr.	10 x 360° = 3600° (+10%)
Widerstandstoleranz	Resistance tolerance	±5 %
Linearitat	Linearity	<0,15 %
Lebensdauer	Rotation life	1 Mill. Umdr. / Turn
Belastbarkeit	Power rating	2 W (40 °C)
Schleiferstrom	Slider current	50 mA
Temperaturkoeffizient	Temperature coefficient	40 ppm / °C nom. (-55 °C +125 °C)
Drehrauschen (ENR)	Rotational noise (ENR)	100 $\Omega$ / 1 mA
Endwiderstande	End resistances	0,5 % R tot. min. 0,5 $\Omega$
Spannungsfestigkeit	Dielectric strength	1500V DC
Einstell Drehmoment	Torque	0,2...0,5 Ncm
Anzugsdrehmoment (Mutter M10)	Torque (Nut M10)	100 Ncm
Gleichlauf	Synchronous run	0,5 %

**Massbild**

Outline drawing

